

# Developing Groundwater Software Model for Well-Hydraulics: A Fundamental Approach

Aman Srivastava<sup>1</sup> Aditya Dhanuka<sup>2</sup> Vijay Motamwar<sup>3</sup> Leena Khadke<sup>4</sup>

B. Tech. Student, Department of Civil Engineering, Government College of Engineering, Jalgaon, India

**Abstract**— From the research, it was studied that one of the saturated formation of the earth material which not only stores water but yield it in sufficient quantity was an aquifer. Wells forms the most important mode of groundwater extraction from an aquifer. Open wells were extensively used for drinking-water supply in rural communities and in small farming operations. Well-hydraulics in confined and unconfined flow for steady and unsteady state of groundwater aims at the determination of discharge and permeability of the aquifer by using field parameters. Field data represented the point measurement whereas hydrological model dealt at catchment or sub-catchment level.

The purpose of this paper was to develop computer-based conceptual groundwater software model for well-hydraulics, a computer-based programming. The approach was to assemble fundamental equations of well-hydraulics like estimating discharge, recuperation of groundwater, well loss, well efficiency and specific capacity of the well into one program that would take into account all those parameters affecting the groundwater hydrology and can simply execute the output. This was going to be a productive methodology for site engineers as instead of collecting data from the field and Analysing it in the office, the same can be achieved on the field itself if this program was brought in practice.

Factors affecting the well represented the parameters. The mathematical interdependencies between these parameters would be used to develop a groundwater software model representing hydraulics of well. Model can be calibrated using field data. Model validation would be based on the comparison of the output of the model from the program with the observed data provided by the standard specification. The overall idea of the paper was to avoid manual calibration and calculation, instead to provide a computer-based program in order to simplify the conception of well-hydraulics. The future scope of this paper was to transmute this software model into an android application for improved use of this contemporary model.

**Keywords**— well, hydraulics, groundwater, hydrology, software model, aquifer, irrigation, agriculture.

## I. INTRODUCTION

Study of the subsurface flow was equally imperative since about 30% of the world's fresh water resources occurs in the form of groundwater. Further, the subsurface water forms a critical contribution for nourishment of life and vegetation in scorched regions. Due to its standing as a significant source of water supply, various characteristic of groundwater dealing with exploration, development and utilization had been broadly studied by workers from different disciplines [1], [2]. In this paper, water in the soil mantle was called subsurface water and considered in two zones. First one was *saturated zone* also called as *groundwater zone*, the space in which all pores of the soil were filled with water. Another one was the *zone of aeration* where soil pores were partially filled with water. This zone was further classified into three subzones- *soil water zone*, *capillary fringe* and *intermediate zone*. The present paper concerned with saturated zone only as shown in Fig. 1. From the groundwater utilization facet, only those resources through which water moves easily and hence substantial extraction was possible with ease were significant. On this basis, saturated formations were classified into four categories [3]:

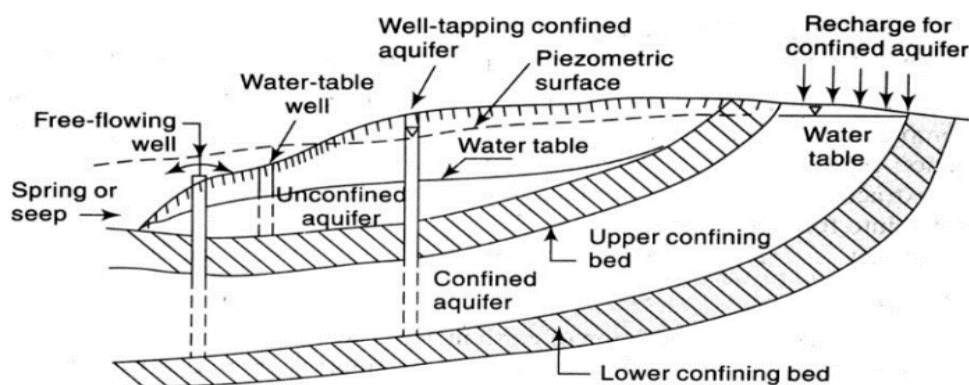

Fig. 1 Confined and Unconfined Aquifer [10]

- A. *Aquifer*: Saturated formation of earth material which not only stores water, but yield it in sufficient quantity. Thus, an aquifer transmits water relatively easily due to its high permeability.
- B. *Aquitard*: It was the formation through which only seepage was possible and thus yield was insignificant compared to an aquifer. It was partly permeable.
- C. *Aquiclude*: It was a geological formation which was impermeable to the flow of water.

D. *Aquifuge*: it was the geological formation which neither porous nor permeable. There are no interconnected openings and hence it cannot transmit water [4].

The availability of groundwater from an aquifer at a place depends upon the rates of withdrawal and replenishment. Aquifer were classified as- an *unconfined aquifer* (also called water table aquifer) was the one in which free water table exists as shown in Fig. 1. Only the saturated zone of this aquifer was of importance in groundwater studies. A well driven into an unconfined aquifer would indicate the static water level corresponding to the water table level at that location. Another one was *confined aquifer* (also called artesian aquifer) was an aquifer which confined between two impervious beds such as aquicludes or aquifuges as shown in Fig. 1. Recharge of this aquifer takes place only in the area where it exposed at the ground surface. The water in the confined aquifer would be under pressure and hence piezometric level would be much higher than the top level of the aquifer. A confined aquifer called a *leaky aquifer* if either or both of its confining beds are aquitard [4].

The important properties of an aquifer are its capacity to release the water held in its pores and the ability to transmit the flow easily. There properties essentially depend upon the composition of the aquifer. Henry Darcy, based on his experimental findings proposed a law relating the velocity of the flow in a medium. This law called *Darcy's Law* (Darcy, 1856) can be expressed as:  $V = K i$  ..... (1)

Where  $V$ =apparent velocity of seepage  $=Q/A$  in which  $Q$ =discharge and  $A$ =cross section of the porous medium;  $i = - (dh/ds)$  =hydraulic gradient, in which  $h$ =piezometric head and  $s$ =distance measured in the general flow direction;  $K$ =coefficient of permeability also designated as hydraulic conductivity, reflects the combined effect of porous medium and fluid properties. From the analogy of laminar flow through a conduit (Hagen-Poiseuille flow, 1840-41 and 1846) the coefficient of permeability can be expressed as:  $K = Cd^2 (\gamma/\mu)$  ..... (2)

Where  $d$ =mean particle size of the porous medium,  $\gamma = \rho.g$ =unit weight of fluid,  $\rho$ =density of fluid,  $g$ =acceleration due to gravity,  $\mu$ =dynamic viscosity of fluid and  $C$ =shape factor which depends upon the porosity, packing, shape of the grains etc. [1], [3], [5].

Aquifers plays the role of both a transmission conduit and a storage. Wells form the most important mode of groundwater extraction from an aquifer. While wells are used in several different applications, they found extensive use in water supply and irrigation engineering practices. *Open wells* also known as *dug wells* are extensively used for drinking water supply in rural communities and in small farming operations they are best suited for shallow and low-yielding aquifers [6].

The objective of this paper was to develop computer- based conceptual groundwater software model for well-hydraulics, a computer-based programming. The approach was to assemble fundamental equations of well-hydraulics (*only steady flow into a well has been considered in this paper*) like estimating discharge, recuperation time of groundwater, well loss, well efficiency and specific capacity of the well (water may be extracted from confined or unconfined aquifer) into one program that would take into account all those parameters affecting the groundwater hydrology and can simply execute the output.

## II. OPERATION OF WELL

Consider the water in an unconfined aquifer being pumped at a continuous rate from a well. Preceding to the pumping the water level in the well designates the static water table. A dropping of this water level take on pumping. If the aquifer was homogeneous and isotropic and the water table initially horizontal, due to the radial flow into the well through the aquifer the water table adopts a tapering shape called *cone of depression*. The depletion in the water table level at any point from its former static elevation called *drawdown*. The areal range of the cone of depression called *area of influence* and its radial range called *radius of influence*. At continual rate of pumping, the drawdown curve advanced progressively with time due to the extraction of water from the storage. This stage called an *unsteady flow* as the level of water table at a given location near the well changed with time. On protracted pumping an equilibrium state was reached between the rate of pumping and rate of inflow of ground water from the outer edges of the zones of influence. The drawdown accomplished a constant position with respect to time when the well known to function under a *steady flow* conditions. As soon as pumping stopped, the reduced storage in the cone of depression made good by ground water incursion into the zone of influence. There was plodding accretion of storage till the original (static) level achieved. This phase was called as *recuperation* or retrieval and was an unsteady phenomenon. Recuperation time depends upon the aquifer physiognomies [4].

Vicissitudes like the above take place to a pumping well in a confined aquifer also but with the variance that it was the piezometric surface instead of water table that experiences drawdown with the progress of the cone depression. In Confined aquifers with necessary piezometric head, the reposition into the well takes place at a very swift rate.

## III. STEADY FLOW INTO THE WELL

The mathematical derivations for the steady state radial flow into the well under both confined & unconfined aquifer conditions were studied [6].

### A. Confined Flow

Well operating in a confined aquifer (WOCA) as shown in Fig. 2 shows a well entirely penetrating a confined aquifer of width  $B$ . Consider well to be discharging a steady flow,  $q$ . The original piezometric head (Static Level) was  $H$  and the drawdown due to pumping is indicated in Fig. 2 WOCA. The piezometric head at the pumping well was  $h_w$  & the drawdown  $S_w$ . At a radial distance  $r$  from the well, if  $h$  is the piezometric elevation, the velocity of flow by Darcy's law:  $V = K(dh/dr)$ . The cylindrical surface through which this velocity occurs is  $2\pi rB$ , hence by equating the discharge entering this surface to the well discharge.

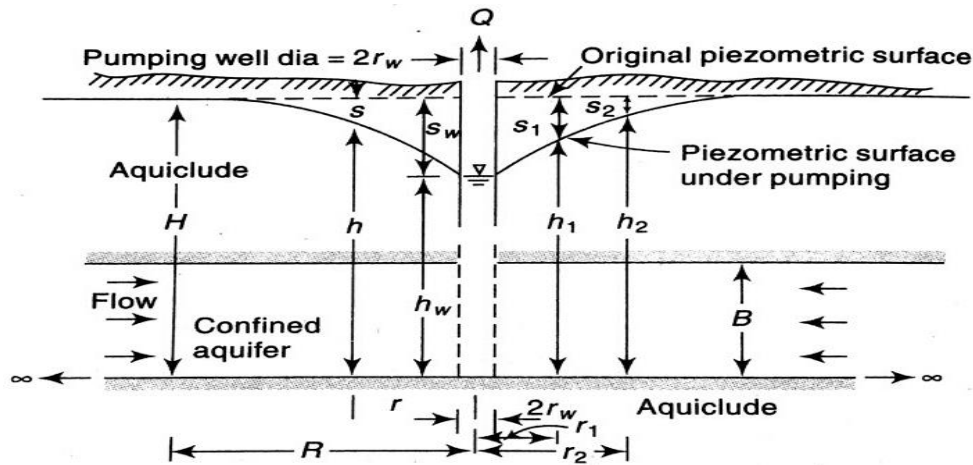

Fig. 2 Well Operating in Confined Aquifer [10]

$$Q = 2 \pi r B K (dh/dr); \text{ therefore, } \int_{r_1}^{r_2} \frac{Q \cdot dr}{2 \pi K B r} = \int_{h_1}^{h_2} dh$$

Integrating between limits  $r_1$  &  $r_2$  with the corresponding piezometric head being  $h_1$  &  $h_2$  respectively, we get,

$$Q = \frac{2 \pi K B (h_2 - h_1)}{\ln \frac{r_2}{r_1}} \dots \dots \dots (3)$$

This was the equilibrium equation for the steady flow in confined aquifer. This equation was popularly known as *Thiem's equation*.

If the draw down  $S_1$  &  $S_2$  at the observation wells are known, then by noting that

$$S_1 = H - h_1 \text{ and } S_2 = H - h_2$$

$T = KB$ , then Eq. 3 would read as

$$Q = \frac{2 \pi K B (s_1 - s_2)}{\ln \frac{r_2}{r_1}} \dots \dots \dots (4)$$

Further at the edge of zone of influence,  $s=0$ ,  $r_2 = R$  &  $h_2 = H$ , at the well wall  $r_1=r_w$ ,  $h_1 = h_2$  &  $S_1=S_w$ . hence, Eq. 4 would be

$$Q = \frac{2 \pi T S_w}{\ln \frac{R}{r_w}} \dots \dots \dots (5)$$

Eq. 4 and 5 can be used to estimate  $T$  and  $K$ , from pumping test. For the use of equilibrium equation (Eq. 3) or its alternative forms, it was necessary that the assumptions of comprehensive penetration of the well into the aquifer and steady state of flow are fulfilled [6], [4]. In order to get the standard data regarding the above parameters follow reference [7], [8], and [9]. Also, refer Table II to IX illustrated in section 6.

**B. Unconfined Flow**

Consider a steady flow from a well entirely penetrating an unconfined aquifer (see Fig. 3). In this case, because of presence of curved free surface, the streamlines are not strictly radial straight lines, while stream lines at the free surface would be curved, the one at bottom of aquifer would be horizontal line, both converging to the well. To obtain a simple solution Dupit's assumptions are considered. In the present case, following are the assumptions [4], [6]:

- 1) For small inclination of free surface, the streamlines can be assumed to be horizontal and the equipotential and thus vertical.

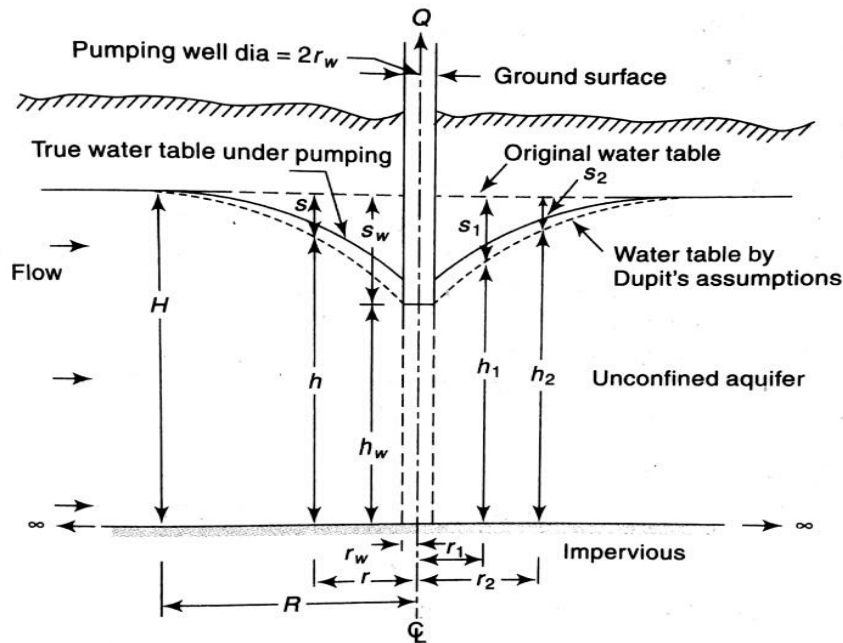

Fig. 3 Operating Conditions of Unconfined Aquifer [10]

$$Q = 2\pi r h V = 2\pi r K h (dh/dr) ; \int_{r_1}^{r_2} \frac{Q \cdot dr}{2\pi K r} = \int_{h_1}^{h_2} h dh$$

- 2) The hydraulic gradient was equal to the slope of the free surface and does vary with the depth. This assumption was satisfactory in most of the floe regions except in the immediate neighbourhood of the well.

Integrating between limits  $r_1$  &  $r_1$  with the corresponding piezometric head being  $h_1$  &  $h_2$  respectively, we got,

$$Q = \frac{\pi K (h_2^2 - h_1^2)}{\ln \frac{r_2}{r_1}} \dots \dots \dots (6)$$

Consider the well radius  $r_w$  penetrating fully a widespread unconfined horizontal aquifer as shown in fig. The well was pumping the discharge  $Q$ . At any radial distance  $r$ , the velocity of radial flow into the well was given by:  $V = K(dh/dr)$  ; Where  $h$  was the height of water table above the aquifer bed at that location. For steady flow by continuity:  
 This was the equilibrium equation for a well in a confined aquifer. At the edge of the zone of influence of the radius  $R$ .  $H =$  saturated thickness of the aquifer, Eq. 6 can be written as

$$Q = \frac{\pi K (H^2 - h_w^2)}{\ln \frac{R}{r_w}} \dots \dots \dots (7)$$

Where  $h_w =$  depth of water in the pumping well of the radius  $r_w$ .

Eq. 6 and 7 can be used to guesstimate satisfactory  $Q$  and permeability of aquifer by means of field data. Designs of water table profile by Eq. 6 however would not be accurate near the well because of Dupit's assumptions. The water table surface calculated by Eq. 6 which involved Dupit's assumptions would be lower than the actual surface. The departure would be substantial in the instantaneous neighbourhood of the well in general, values of  $R$  in the range 300 to 500 m can be assumed depending on type of aquifer & operating condition of the well as the logarithm of  $R$  was used in the estimation of discharge, a small error in  $R$  would not utterly affect the approximation of  $Q$ . It should be noted that it taked fairly long time of pumping to attain a steady state in a well in an unconfined aquifer. The retrieval after the termination of pumping was also slow compared to the response of an artesian (confined) well which was comparatively fast [4], [6]. In order to get the standard data regarding the above parameters follow reference [7], [8], and [9]. Also, refer Table II to IX illustrated in section 6.

#### IV. OPEN WELL

Open wells were extensively used for drinking water supply in rural communities & in small farming operations. They were best suitable for shallow and diminutive yielding aquifers. In hard rock the cross section were circular or rectangular. They were largely sunk to a depth of 10 m and were lined wherever unfastened over burden was met. The flow into the well is through joints, fissures and such other openings and was usually at the bottom/lower portions of the well. In unconsolidated formation, the wells were usually dug to the depth of about 10m below water table. Circular in cross section and were lined. The water entry into these well was from the bottom. These well bangs water in unconfined aquifers [7].



When a water in an open well was pumped out the water table inside the well was decreased and the difference in the water table level and the water elevation inside the well was called as *depression head* and expressed as:

$$Q = K_o H \dots\dots\dots (8)$$

Where the proportionality constant  $K_o$  depended on the physiognomies of aquifer and the area of the well. Also since  $K_o$  represented discharge per unit draw down it was called *specific capacity of the well*. There was a *critical depression head* for a well beyond which any higher depression head would cause dislocating of soil particles by the flow velocities. The discharge corresponding to the critical head was called as *critical or maximum yield*. Allowing factor of safety, a working head was specified and corresponding yield from well was known as *safe yield*.

A. *Recuperation Test*

The objective was to determine *specific capacity*  $K_o$  of well using recuperation test explicated below: Let the well be pumped at a continual rate  $Q$  till a drawdown  $H_1$  was obtained as shown in Fig. 4. The pump was now stopped and the well was left to recuperate. The water depth in the well was measured at various time intervals  $t$  starting from stopping of the well.

$H_1$ =drawdown at the start of recuperation,  $t=0$ ;  $H_2$ =drawdown at time,  $t=T_o$ ;  $h$ =drawdown at any time  $t$ ;  $\Delta h$ =decrease in drawdown on time delta  $t$ . At any time,  $t$  the flow into the well was,  $Q = K_o H$

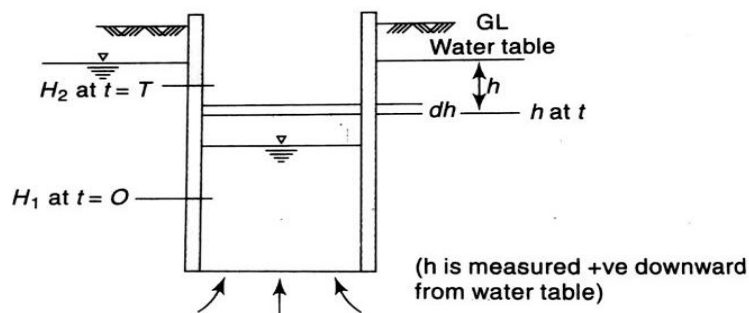

Fig 4. Recuperation of Well [10]

a time, interval  $\Delta t$  causing a small change delta  $\Delta h$  in the water level,

$$Q_o \Delta t = K_o H_o \Delta t = -A \Delta h$$

Where  $A$  was the area of the well. In differential form

$$dt = \frac{- (A dh)}{K_o h}$$

Integrating for time interval  $T_r$ ,

$$\int_0^{T_r} dt = - \frac{(A)}{K_o} \int_{H_1}^{H_2} \frac{dh}{h}$$

$$T_r = \frac{A}{K_o} \ln \frac{H_1}{H_2} \dots\dots\dots (9)$$

$$\frac{K_o}{A} = \frac{1}{T_r} \ln \frac{H_1}{H_2} \dots\dots\dots (10)$$

The term  $K_o/A = K_s$  represented *specific capacity per unit well area* of the aquifer and was essentially a property of aquifer. Knowing  $H_1$ ,  $H_2$  and the recuperation time  $T_r$  for reaching  $H_2$  From  $H_1$  and specific capacity per unit well area calculated by Eq. 10.

Frequently, the  $K_s$  of an aquifer, resolved by recuperation tests on one or more wells, was used in designing further *dug wells* in that aquifer. However, when such information was not available the following approximate values of  $K_s$ , given by *Marriot*, (refer Table I) were often used.

TABLE I  
 SPECIFIC CAPACITY PER UNIT WELL AREA OF SOME SOIL

Type of sub soil	Values of $K_s$ in units of $h^{-1}$
Clay	0.25
Fine Sand	0.50
Coarse Sand	1.00

The yield  $Q$  from an open well under a depression head  $H$  was obtained as

$$Q = K_s AH \dots \dots \dots (11)$$

For dug wells with masonry side walls, it was usual to assume the flow was entirely from the bottom and as such  $A$  in Eq. 10 represented the bottom area of the well [4][6]. In order to get the standard data regarding the above parameters follow reference [7][8]and [9]. Also, refer Table II to IX illustrated in section 6.

**V. WELL LOSS, EFFICIENCY AND CAPACITY**

**A. Well loss**

When the water was pumped out of well, the drawdown due to flow of water through the well screen and axial movement within the well was also considered. In a pumping artesian well, the total draw down at the well  $S_w$ , can be made up of three parts:

- 1) Head drop required to cause laminar porous media flow, called *formation loss*,  $S_{wl}$
- 2) Drop of piezometric head required to sustain turbulent flow in the region nearest to the well where the Reynolds number may be larger than unity,  $S_{wt}$ ; and
- 3) Head loss through the well screen and casing,  $S_{wc}$ .

Of these three  $S_{wl}$  was directly proportion to  $Q$  and ( $S_{wt}$  and  $S_{wc}$ ) directly proportion to  $Q^2$

$$S_w = C_1Q + C_2Q^2 \dots \dots \dots (12)$$

Where  $C_1$  and  $C_2$  were constants for the given well while the first term  $C_1Q$  was the formation loss, the second terms  $C_2Q^2$  was termed *well loss*.

**W. Well Efficiency**

The magnitude of a well loss had an important compartment on the pump efficiency. Abnormally high value of the well loss indicated the clogging of the well screens, etc. and required immediate remedial actions. The coefficients  $C_1$  and  $C_2$  were determined by pump test data of drawdown for various discharges.

The well loss was the measure of competence of the well that was defined as *well efficiency* ( $\eta$ ):

$$\eta = \frac{\text{formation loss}}{\text{total drawdown measured inside the well}} ; \eta = S_{wl} / (S_{wl} + S_{wc} + S_{wt})$$

$$= \frac{C_1Q}{C_1Q + C_2Q^2} \dots \dots \dots (13)$$

**X. Specific Capacity**

The discharge of the water inflow per unit drawdown at the well ( $Q/S_w$ ) was known as *specific capacity* of a well and was the measure of recital of the well. For confined and unconfined aquifer under equilibrium conditions and neglecting well losses, we could obtain specific capacity from the equation 5 and 7.

However, for the common case of a well discharge in the constant rate  $Q$  under unsteady drawdown conditions, the specific capacity was given by:

$$\frac{Q}{S_w} = 1 \div \left\{ \frac{1}{4\pi T} \ln (2.25 T t / r_w^2 \cdot S) + C_2Q \right\} \dots \dots \dots (14)$$

Where  $t$  = Time after the start of pumping. The term  $C_2Q$  was to account for *well loss*. The specific capacity depends upon  $T$ ,  $s$ ,  $t$ ,  $r_w$  and  $Q$ . Further, for a given well it was not a constant, but decreases with increases in  $Q$  and  $t$ . In order to get the standard data regarding the above parameters follow reference refer TABLE II to IX illustrated in section VI.

**VI. GROUNDWATER SOFTWARE MODEL FOR WELL-HYDRAULICS**

Following were the broad steps adopted for developing simulation model using C-language along with the working of the programme in the flowchart (as shown in Fig. 5):

- A. Enter the type of aquifer- (a) Confined; (b) Unconfined. If option (a) was entered, then information (field data) of confined aquifer must be entered in the next step.
- B. Enter the values of (a) thickness of aquifer( $B$ ). (b) coefficient of permeability( $K$ ). (c) drawdown ( $S_w$ ). (d) radius of influence at drawdown ( $r_w$ ). And option (e) exit.
- C. Enter the value of  $R$  (radius of influence at edge of zone of influence). If it was not available, then calculate  $R$  using empirical relation-  $R = 3000 \cdot S_w \cdot K^{\frac{1}{2}}$ .

- D. Obtain the value of discharge  $Q = \frac{2\pi T S_w}{\ln \frac{R}{r_w}}$  Where  $T=KB$ .
- E. If user wanted to find out other properties of well then pressing enter would generate these options-(a) specific capacity of well ( $K_0$ ). (b) well loss. (c) well efficiency ( $\eta$ ). (d) recuperation time of well.
- F. In case of option (a),  $K_0 = \frac{Q}{S_w}$ .
- G. In case of option (b), enter the value of  $C_2$  and obtain the well loss using the equation  $Well\ Loss = C_2 Q^2$ .
- H. In case of option (c), enter the value of  $C_2$  and obtain the efficiency using the equation  $\eta = 1 - \frac{Well\ Loss}{S_w}$ .
- I. In case of option (d), enter the value of  $H_1$  (drawdown at the start),  $H_2$  (drawdown at the end of time) and obtain the value of recuperation time (specific capacity per unit well area ( $K_0/A$ ) can also be obtained) by using the equation:  

$$T = \frac{A}{K_0} \ln \frac{H_1}{H_2}$$

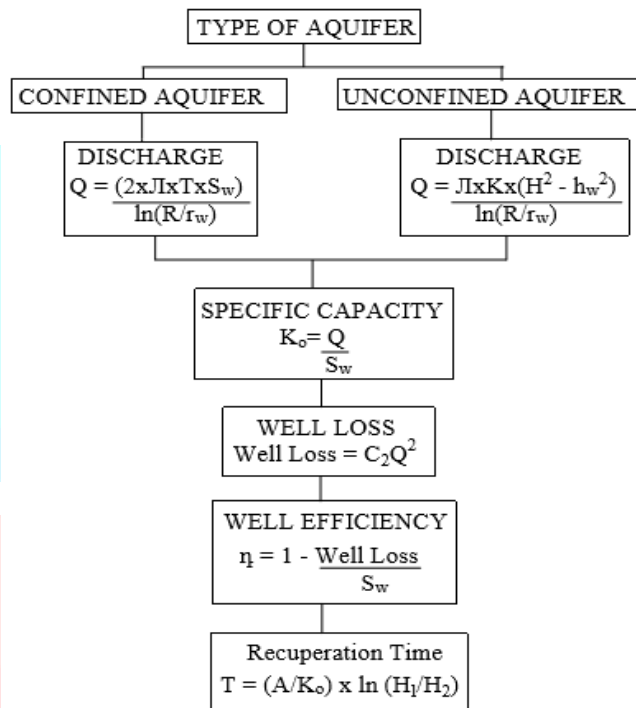

Fig. 5: Flowchart of Groundwater Software Model for Well Hydraulics

In the similar fashion, for unconfined aquifer as described in the flowchart in Fig. 5, the program was developed. The changes lie in the use of fundamental equation for calculating discharge and rest of the equations remained the same, (that we have already mentioned which we would be considered in this case).

To accomplish the model calibration and its validation the data that brought in use are mentioned below. The sources of the data have been taken from the references [7], [8], [9], [10]. Some of the tables were illustrated from the references which was mentioned in the Table II to IX listed below:

TABLE II  
 POROSITY AND SPECIFIC YIELD OF SELECTED FORMATIONS

Formation	Porosity %	Specific yield %
Clay	45-55	1-10
Sand	35-40	10-30
Gravel	30-40	15-30
Sand Stone	10-20	5-15
Shale	1-10	0.5-5
Lime Stone	1-10	0.5-5

TABLE III  
 REPRESENTATIVE VALUES OF THE PERMEABILITY COEFFICIENT

No.	Material	K (Cm/S)	Ko (Darcy's)
-----	----------	----------	--------------

A. Granular Material			
1	Clean Gravel	1 – 100	$10^3 - 10^5$
2	Clean Coarse Sand	0.01 – 1	$10 - 10^3$
3	Mixed Sand	.005 - .01	5 – 10
4	Fine Sand	.001 - .05	1 – 50
5	Silty sand	$10^{-4} - 2 \times 10^{-3}$	.1-2
6	Silt	$10^{-5} - 5 \times 10^{-4}$	0.01-0.5
7	Clay	$<10^{-6}$	$<10^{-3}$
B. Consolidated material			
1	Sand Stone	$10^{-6}-10^{-3}$	$10^{-3}-1$
2	Carbonate rock with secondary porosity	$10^{-5}-10^{-3}$	$10^{-2}-1$
3	Shale	$10^{-10}$	$10^{-7}$
4	Fracture and Weathered rock (aquifers)	$10^{-6}-10^{-3}$	$10^{-3}-1$
At 20 <sup>0</sup> C, For water, $\nu = 0.01 \text{ cm}^2/\text{s}$ , $K_0 = 10^3 \text{ K Cm/S}$ at 20 <sup>0</sup> C			

TABLE IV  
NORMS FOR SPECIFIC YIELD ( $S_y$  PERCENTAGE)

No.	Description of the area	Recommended Value	Minimum Value	Maximum Value
1	Alluvial areas			
	Sandy alluvium	16	12	20
	Silty alluvium	10	8	12
2	Hard Rock areas			
	Weather Granite, gneiss and schist			
	With low clay content	3	2	4
	With significantly clay content	1.5	1	2
	Weathered or vesicular, Jointed basalt	2	1	3
	Laterite	2.5	2	3
	Sandstone	3	1	1
	Quartzite	1.5	1	2
	Limestone	2	1	3
	Karstified Limestone	8	5	15
	Phyllites, Shales	1.5	1	2
	Massive, poorly fractured rock	0.3	0.2	0.5

TABLE V  
NORMS FOR SELECTION OF RAINFALL FACTOR F

No.	Area	Value of $f$ in percentage		
		Recommended value	Minimum value	Maximum value
1	Alluvial areas			
	Indo-Gangetic and Inland areas	22	20	25
	East coast	16	20	18
	West coast	10	8	12
2	Hard rock areas			
	Weathered granite, gneiss & schist with low clay content	11	10	12
	Weathered granite, gneiss & schist with significant clay content	8	5	9
	Granulite facies like charnokite etc.	5	4	6
	Vesicular & Jointed basalt	8	5	9
	Weather basalt	5	4	9
	Laterite	13	12	14
	Semi-consolidated sand stone	7	6	8
	Consolidated sand stone, quartzite, limestone	7	6	8
	Phyllites, Shales	12	10	14
Massive poorly fractured rocks	6	5	7	



TABLE VI  
RECHARGE DUE TO SEEPAGE FROM CANALS

1	Unlined canals in sandy soil with some silt content	<ul style="list-style-type: none"> <li>• 1.8 to 2.5 m<sup>3</sup>/million sq. M of wetted area</li> <li>• 15-20 ha. m/day/million sq. M of wetted area</li> </ul>
2	unlined canals in normal soils with some silt content	<ul style="list-style-type: none"> <li>• 3 to 3.5 m<sup>3</sup>/ million sq. M of wetted area</li> <li>• 25 - 30 ha. m/day/million sq. M of wetted area</li> </ul>
3	Lines Canals and canals in hard rock areas	<ul style="list-style-type: none"> <li>• 20% of above values for unlined canals</li> </ul>

TABLE VII  
RECHARGE FROM IRRIGATION

Source for irrigation	Type of crop	Recharge as percentage application		
		Water table below Ground level		
		<10m	10-25m	>25m
Groundwater	Non-paddy	25	15	5
Surface water	Non-paddy	30	20	10
Groundwater	Paddy	45	35	20
Surface water	Paddy	50	40	25

TABLE VIII  
RECHARGE FACTORS FOR TANKS AND OTHER WATER HARVESTING STRUCTURES

Sr. No.	Structure	Recharge Factor
1	Recharge from storage tanks/ponds	1.4 mm/day for the period in which the tank has the water, based on the average area of water spread. If the data on average water spread is not available, 60% of the maximum water spread area may be used.
2	Recharge from percolation tanks	50% of gross storage considering the number of fillings. Half this value of recharge is assumed to be occurring during monsoon season.
3	Recharge due to check dams and Nala bunds	50% of gross storage. Half the value of recharge is assumed to be occurring during monsoon season

TABLE IX  
CATEGORIES OF GROUND WATER DEVELOPMENT

Category	% of ground water development	Long term decline of pre- & post monsoon ground water levels
Safe	<70%	Not significant
Semi-critical	70% to 90%	Significant
Critical	90% to 100%	Significant
Over-Exploited	>100%	Significant

## VII. RESULT ANALYSIS

A problem was solved by using the equations (mentioned in section III to VI) manually and then obtained result was analysed with the software model discussed in order to validate the program for solving the problems of well-hydraulics.

### A. Problem on Unconfined Aquifer:

A 45cm well penetrates an unconfined aquifer having the saturated head of 30m. The radius of influence is 300m for open well. Given the permeability of the aquifer is 20m/day. After the steady pumping rate the level of the water in the well dropped down by 2.5m and recuperated by 1.8m having the drawdown at well is 3m.

Determine the following parameters:

1. Discharge
2. Specific capacity
3. Well loss
4. Well efficiency
5. Recuperation time

Assume the coefficient of the well loss to be 0.5.

### B. Problem for Confined Aquifer:

A 20cm diameter well fully penetrates a confined aquifer of 30m depth. The radius of influence for the open well is 300m. Given coefficient of permeability is 25.18m/day. After the steady pumping rate the level of the water in the well dropped down by 4m and recuperated by 3.6m having the drawdown at well is 6m.

Determine the following parameters:

1. Discharge
2. Specific capacity
3. Well loss
4. Well efficiency
5. Recuperation time

Assume the coefficient of the well loss to be 0.5.

*Solution by Manual Calculation:* Using the equations mentioned in section III to VI, both the problem was solved manually whose results were tabulated in Table X as shown below:

TABLE X  
RESULT OF MANUAL CALCULATION FOR CONFINED AND UNCONFINED AQUIFER

Characteristics/ Type of Aquifer	Unconfined	Confined
Diameter of Well ( $D_w$ )	0.45m	0.20 m
Width of Aquifer (B / H)	30 m	30 m
Radius of Influence (R)	300 m	300 m
Drawdown at Well ( $S_w$ )	3 m	6 m
Permeability of Soil (K)	$2.3148 \times 10^{-4}$ m/s	$2.914 \times 10^{-4}$ m/s
Depth of Depression of Water in Well ( $H_1$ )	4 m	4 m
Depth of Recuperation of Water in Well ( $H_2$ )	$(4-3.6) = 0.4$ m	$(4-3.6) = 0.4$ m
<b>Results</b>		
Discharge	$0.15938 \text{ m}^3/\text{s}$	$0.0411 \text{ m}^3/\text{s}$
Specific Capacity	$0.00531 \text{ m}^2/\text{s}$	$6.8604 \times 10^{-3} \text{ m}^2/\text{s}$
Well Loss	1.27%	0.0844%
Well Efficiency	99.57%	98.59%
Recuperation Time	68.96 sec	10.54 sec

*Solution by Software Program Developed in this research:* The problem of the unconfined aquifer given above was solved using the program by adopting the same methodology explained in the section VI. The screenshots of the solved problem shown in Fig. 6, Fig. 7 and Fig 8 summarized below:

```

Enter the value of H = 30
Enter the value of h =27
Enter the value of sw = 3
Enter the value of rw = 0.225
Do you Have value of R : (y or n) y
Enter value of R:300
Discharge is : 0.01593
MENU
1.Enter Specific Capacity:
2.Enter Well Loss:
3.Enter Well Efficiency:
4.Enter Recuperation Time:
0.Exit
Enter the choice : 4
Enter value of H1:4
Enter value of H2:0.4
Recuperation Time:68.929619

```

Fig. 6 Screenshot for Calculation of Discharge and Recuperation time

```

Do you Have value of R : (y or n) y
Enter value of R:300
Discharge is : 0.01593
MENU
1.Enter Specific Capacity:
2.Enter Well Loss:
3.Enter Well Efficiency:
4.Enter Recuperation Time:
0.Exit
Enter the choice : 1
Specific capacity : 0.00531
Do you want to continue : (y/n) :y
MENU
1.Enter Specific Capacity:
2.Enter Well Loss:
3.Enter Well Efficiency:
4.Enter Recuperation Time:
0.Exit
Enter the choice : 2
Enter value of c2:0.5
Well Loss: 0.000127

```

Fig. 7 Screenshot for Calculation of Specific Capacity and Well Loss

```

Specific capacity : 0.00531
Do you want to continue : (y/n) :y
MENU
1.Enter Specific Capacity:
2.Enter Well Loss:
3.Enter Well Efficiency:
4.Enter Recuperation Time:
0.Exit
Enter the choice : 2
Enter value of c2:0.5
Well Loss: 0.000127
Do you want to continue : (y/n) :y
MENU
1.Enter Specific Capacity:
2.Enter Well Loss:
3.Enter Well Efficiency:
4.Enter Recuperation Time:
0.Exit
Enter the choice : 3
Enter value of c2:0.5
Well Efficiency:0.999958

```

Fig. 8 Screenshot for Calculation of Well Loss

By comparing the measured values so obtained using manual calculation with the values so obtained from the above program, we concluded that there was no variation in the result of these two approaches. Hence, the program developed in this paper was found consistent with the methodology so adopted with respect to the hydrological equation of the rainfall-runoff process.

### VIII. CONCLUSIONS

The groundwater simulation model developed in this paper afforded a fundamental approach of analytical cum mathematical modelling using computer-based programming. The empirical relations and the different formulae of well hydraulics cast-off in this paper were already in existence and was attained from the standard references. This had been referred for the purpose of simulating the model using computer programming in order to eliminate time consuming tedious manual calculations. This paper tried to associate the fundamental notion of the subject-*Well Hydraulics* with the computer-based programming.

The mathematical interdependencies between the parameters involved had resulted into formula (*modelling*) by numerous researchers which was amassed in this paper into a groundwater simulating model. When the parameters of the delinquent area (input) was applied over the model (*model calibration*), the program interpreted the data (processing) and relieved the information into the obligatory formula already defined in the program which produced one of the result (output) for which the data was processed. The output was compared with observed data (*model validation*) provided by the standard specification like that of the report of *Groundwater Resources Estimation Committee, Ministry of Water Resources, GOI* etc. As this was an empirical cum numerical approach of estimating the properties of well, hence the output obtained from this model would vary if the characteristics considered here have another formula (empirical or numerical) w.r.t. some other field conditions. Therefore, the model was limited to give result of only those conditions for which the corresponding formula had been considered.

Hence, it can be concluded that the methodology of understanding the conceptions of well hydraulics provided a preliminary approach to the undergraduates to link the practical on wells with computer programming to develop their interdisciplinary approach towards learning. The future scope of this paper was to transmute this simulation model into an android application for improved use of this contemporary model.

### REFERENCES

- [1] Bauwer H., *Groundwater Hydrology*, McGraw-Hill Kogakusha, Tokyo, 1978.
- [2] Davis S.N., *Hydrogeology*, John Wiley and Sons; New York, 1966
- [3] Bear J., *Hydraulics of groundwater*, Dover Publication, 2007.
- [4] Subramanya K., *Engineering Hydrology*, Tata McGraw Hill, New Delhi, India, 2009.

[5] Halek V. and J. Svec, *Groundwater Hydraulics*, Elsevier; Amsterdam, 1979.  
[6] Garg S.K., *Irrigation Engineering and Hydraulic Structure*, Khanna Pub, Delhi, 2014  
[7] Central Water Commission, *Water resources of India*, CWC pun. No. 30/88, April 1988, New Delhi, India.  
[8] Ministry of Water Resources, *GOI report of Groundwater Resources Estimation Committee, Ministry of Water Resources*, [9] Groundwater Resource Methodology, New Delhi, 1997.  
[10] Ministry of Water Resources, *GOI report of National Commission for Integrated Water Resources Development, Vol-1*, New Delhi, 1999.

