



INTERNATIONAL JOURNAL OF CREATIVE RESEARCH THOUGHTS (IJCRT)

An International Open Access, Peer-reviewed, Refereed Journal

Development Of Two-jaw Pneumatic Gripper

Prof. Shrikant Ghatiga¹, Humera Shaikh², Dhanashri Pawar³

¹Asst. Professor Mechanical Engineering Vidya Prasarini Sabha's College of Engineering and Technology, Lonavala

²Student Mechanical Engineering Vidya Prasarini Sabha's College of Engineering and Technology, Lonavala

³Student Mechanical Engineering Vidya Prasarini Sabha's College of Engineering and Technology, Lonavala

Abstract:

The handling of abstract materials and mechanisms to pick and place are widely found in factory automation and industrial manufacturing. There are different mechanical grippers which are based on different motor technologies have been designed and employed in numerous applications. The designed robotic gripper in this paper is a two jaw actuated gripper which is different from the conventional cam and follower gripper in the way that controlled movement of the jaws is done with the help of pneumatic cylinders using air pressure. The force developed in the cylinder is very gentle and is directly delivered to the jaws in a compact way. The design, analysis and fabrication of the gripper model are explained in details along with the detailed list of all existing pneumatic grippers in market. The force and torque for the gripper have been calculated for different set of conditions. The working of the model is checked for and observation for pay load is recorded at various pressures. The highly dynamic and highly accelerated gripper model can be easily set at intermediate positions by regulating the pressure. Pneumatic grippers are very easy to handle and are generally cost- effective because air hoses, valves and other pneumatic devices are easy to maintain.

Keywords: Automation, air hoses, Ansys, gripper, jaws, Pro-E.

1.INTRODUCTION

Compressed Air is the air under pressure having values much greater than that of the atmosphere. When this compressed air is expanded to a lower pressure, a piston can be pushed using it, such as that in a jackhammer; it can go through small air turbines to turn shaft, as in a high-speed dental drill; or it can be expanded through a nozzle to produce a high-speed jet as in a paint sprayer. There are many pneumatic devices in which compressed air becomes a source of energy to perform various operations which includes riveting guns, air powered hammers, drills such as rock drills and other air powered tools. There are methods to use compressed air in coal mining tools thus reducing any chances of explosion which happens in case of electric tools which generally produces spark.

II.WORKING PRINCIPLE

The parallel jaw gripper has at least two fingers which can be moved towards each other along one axis. Usually, the fingers can be moved independently from each other in order not to shift the object, but they are only able to perform simple operations like open and close. Thereby, a longitudinal or side movement is impossible. A parallel jaw perform, a manual control to steer the gripper must be possible for enabling the highest flexibility.

- The principles which are followed in this type of parallel jaw gripper are:

The force closure grip:

- The characteristic of the force closure grip is that the gripper keeps the object in a stable state by compensating all forces and torques created by the object. The sum of all forces and sum of all torques must equal zero ($\sum F=0; \sum M=0$).

The force closure grip can be differentiated into a grip with friction and without friction. The force closure grip without friction is much idealized and not very common in daily use; therefore it is no further mentioned. The force closure grip with friction requires at least contact points for gripping a planar object and at least 4 contact points for a three-dimensional object

- The form closure grip is the second principle for gripping objects. This grip is feasible, because the gripper is a negative model of the object (or a part of it) which limits the movement of the object within the gripper in any direction, also when changing the gripper orientation.
- The force is compensated on well specified contact surfaces. Tangential load, pressure load and torque are not considered, but are instead reduced to the corresponding forces. The gripper must either make use of a special geometry (i.e. negative model of the object), or a significant number of fingers are required.

When compressed air is released from the compressor through the pressure regulator, it rapidly flows into the 5/2 way valve. The desired pressure level can be maintained by observing the pressure readings on the dial gauge. The maximum pressure at which the system can be operated is 10 bar, but mostly we will be working at pressure levels far below that, preferably less than 5 bar. The compressed air moves into the 5/2 way valve which when activated either manually or by solenoid electric circuit allows the compressed air into the inlet port of the two double acting air cylinder(max supply pressure of 10 bar) which are placed exactly opposite to each other. A 5/2 way valve could be used in place of a 5/3 way valve which is an advanced valve which regulates the amount of compressed air flow, thus controlling the stroke length of the piston rods. The cylinder has a bore diameter of 50 mm and stroke of 50 mm too.

The entry of air into the cylinder pushes the piston and thus the piston rods undergo a power stroke to move outwards which increases the distance between the gripper surfaces. Thus this movement opens the grippers which helps in releasing the object. For the other way round, when the compressed air flow is reversed then the air flows out from the cylinder into the valve and into the compressor through the regulator. This accounts for the return stroke of the piston rod which helps to grasp the load as the distance between the gripper surfaces decreases. The pressure is maintained as per the gripping force which is required. The distance between the grippers is the width of the object which is required to be grasped.

III.ROBOTIC GRIPPERS

These are the type of robots which have the capability to grasp definite objects and then reposition it according to requirement. The robotic grippers have two basic parts. They are the manipulators and end effectors. The manipulators are the working arm of the robot whereas the End effectors are the hands of the robot. Generally the robots are connected with replaceable end effectors for which they can perform wide range of functions with same fixed manipulators. The end effectors are actuated by various mechanisms which include mechanical drives, electrical drives, hydraulic drives and Pneumatic drives. Among this the widely used one is the hydraulic grippers but the most favorable one is the pneumatic gripper.

A robot gripper is a type of end of arm tooling (EOAT). It is used to pick up items and can be customized for your application. One of the most important aspects of the robot is its EOAT (End of Arm Tooling). A robot gripper serves as the physical interface that a robot performs an application.



Fig.1 Robotic gripper

➤ There are four robot gripper types:

- Vacuum grippers,
- Pneumatic grippers,
- Hydraulic grippers,
- Servo-electric grippers.

IV.GRIPPER FORCE REQUIREMENTS

The type of gripper jaws which is used generally has a major role in determining the force which is required in the functioning of a gripper. The gripper jaws are generally of 2 types or are found in two styles:

- Friction grip
- Encompassing grip.

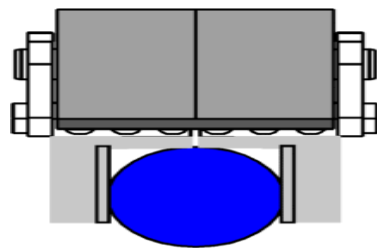

Friction Grip

Fig.2 Friction grip

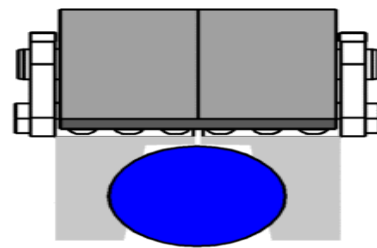

Encompassing Grip

Fig.3 Encompassing grip

1. Calculations:-

Gripping force: - $2\mu Fg=mg$

Max actuating force: - $F= P_a*(\pi D^2/4)$

V.CIRCUIT CONNECTION

This is how a pneumatic robotic gripper acts and the calculations required for the design are as follows

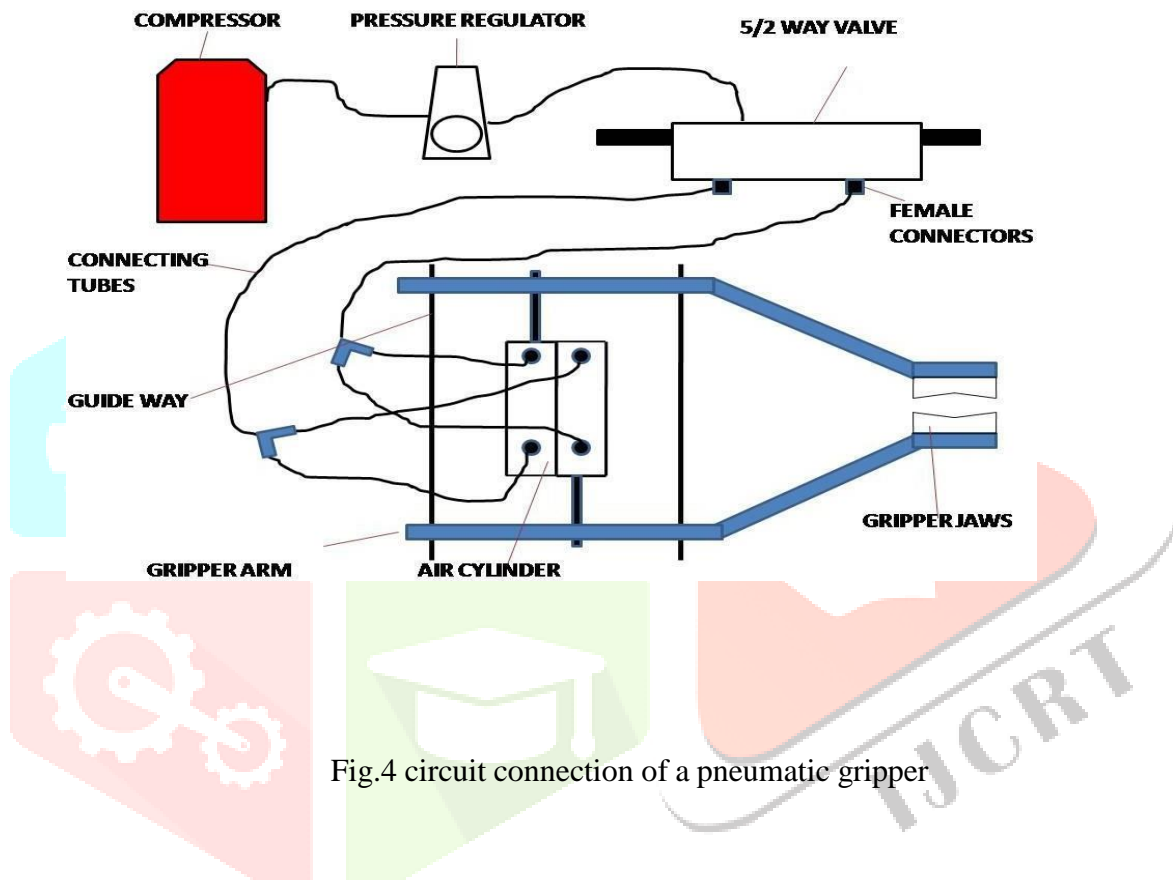

Fig.4 circuit connection of a pneumatic gripper

2. Design of pneumatic gripper developed in pro-e wildfire 5.0

➤ Used commands:

- Line,
- Circle,
- Fillet/chamfer,
- Trim/modify,
- Extrude/remove,
- Revolve. Etc....

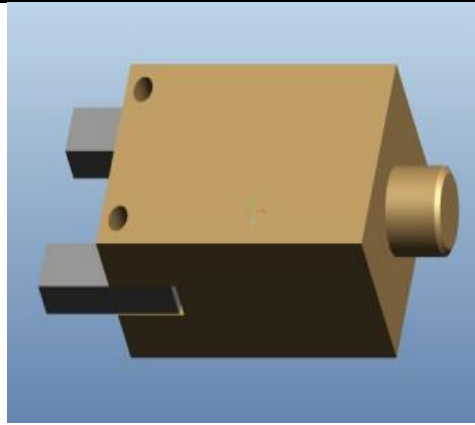

Fig.5 Pneumatic gripper developed in pro-e wildfire 5.0

1. Analysis of pneumatic gripper

➤ Used steps:

- Preferences, (here we will give material properties and method of analysis)
- Pre processor, (here we will apply loads by fixing the model)
- Post processor (here the total results are viewed)
- Gripper design imported from pro-e to ansys

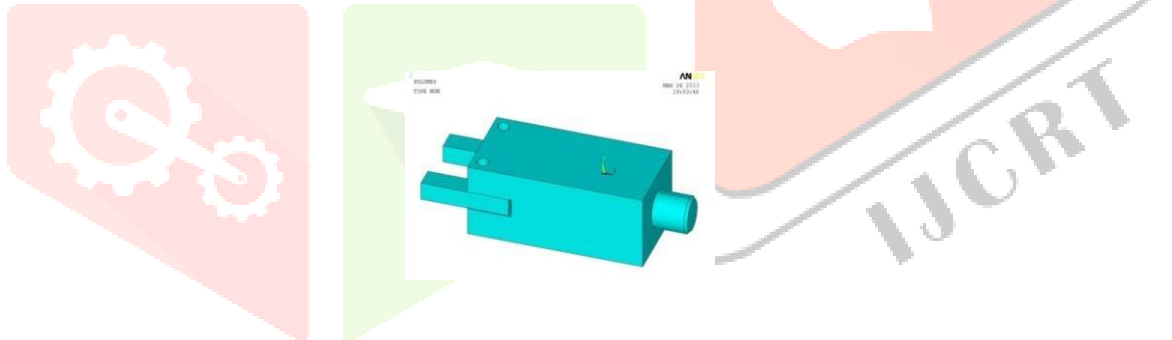

Fig.6 imported pneumatic gripper model in ansys

- Meshed design in ansys

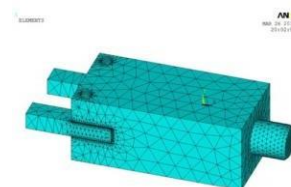

Fig.7 meshed model in ansys

3.Results & discussion

- Analysis of nodal points on gripper jaws in ansys

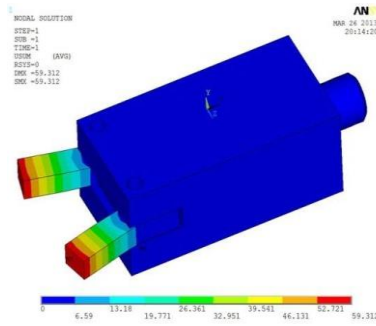

Fig.7 Deformed shape

Maximum absolute values

NODE	87	838	88	69
VALUE	12.741	1.7639	58.175	59.312

- Analysis OF STRESS INTENSITY IN ANSYS

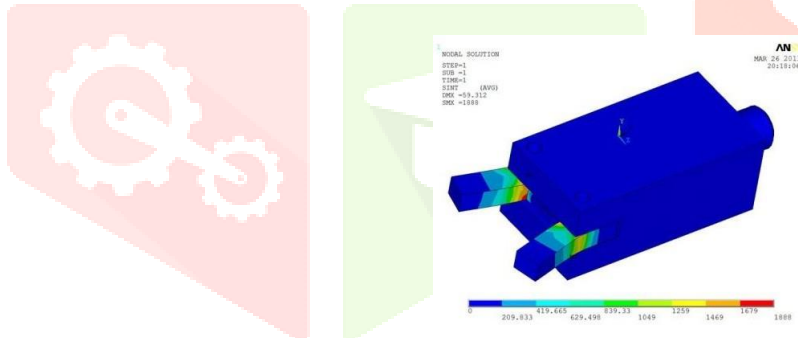

Fig.8 Stress intensity

Minimum values

NODE	3819	767	1027	1	1.0
VALUE	-76.167		-325.64	-1412.7	0.0000
					0.000

Maximum values

NODE	3570	630	4232	3784	3570
VALUE	1732.0	442.0	95.273		1678.
		1		1829.	8

- Analysis of von-mises forces in ansys

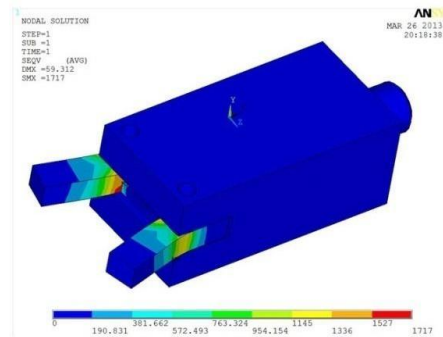

Fig.9 von-mises forces values

Minimum values

NODE	3819	767	1027	1	1
VALUE	-	-	-1412.7	0.000	0.000
	76.167	325.64		0	0

Maximum values

NODE	3570	630	4232	3784	3570
VALUE	1732.0	442.01	95.273	1829.1	1678.8

4.CONCLUSION

From the model we have found out that the pneumatic gripper has many advantages and is one of the modern techniques in the world of robotics which makes pick and drop work easier and much faster than the conventional techniques.

Highly dynamic operation and high acceleration possible. Intermediate positions can be set easily by regulating pressure. Easy to handle thin sheets and other low dimension materials which require intelligent handling. Low cost The Pneumatic grippers offer the most attractive features and are a common choice and this explanation can be inferred from the work carried out in the project. The gripper’s arms were made of steel which allowed the gripper to be lightweight, yet durable for machine loading of metal parts. Such Pneumatic grippers are generally cost-effective because air hoses, valves, and other pneumatic devices are easy to maintain. Replaceable finger inserts for the gripper fingers can be manufactured from

a variety of materials in future to ensure gentle part handling and a firm grip. Different types of gripping surfaces, gripping materials and different dimensions of gripping arm can be made to test the gripping force of the pneumatic robotic gripper.

REFERENCES

- [1]. http://www.io.com/~hcexres/textbook/class_ex.html
- [2]. Besel, Michael N. "Automation." Microsoft® Student 2007 [DVD].
- [3]. Microsoft ® Encarta ® 2007. © 1993-2006 Microsoft Corporation. All rights reserved.
- [4]. Industrial Robotics, Technology, Programming and Applications, Authors-Mikell P.Groover, Mitchell Weiss, Roger N.Nagel, Nicholas G. Odrey.
- [5]. A Sensor-Based Robotic Gripper for Limp material Handling by Ramesh Kolluru, Al Steward, Micheal J. Sonnier and Kimon P. Valavanis , Robotics and Automation Laboratory(RAL), Apparel CIM Centre and CACS, University of Southwestern Louisiana.
- [6]. A Robust Sliding mode Control for Pneumatic Servo Systems by Junbo Song and Yoshihisa Ishida, Department of Electronics and Communication, Faculty of Science and Technology, Meiji University.
- [7]. Mechatronic systems:Automotive applications and modern design methodologies by Werner Dieterle, Robert Bosch GmbH, Automotive Electronics, Driver Assistance Systems, Leonberg, Germany.
- [8]. Accurate Position Control of a Pneumatic Actuator Using On/Off Solenoid Valves by Robert B. van Varseveld and Gary M. Bone.
- [9]. Accurate Position Control of a Pneumatic Actuator by Jiing-Yih Lai, Graduate Associate, Chia-Hsiang Menq, Assistant Professor mem ASME and Rajendra Singh, Professor Mem. ASME Fluid Power Laboratory, Department of Mechanical Engineering, The Ohio State University, Columbus, Ohio
- [10]. Design And Control Of A Robotic Leg With Braided Pneumatic Actuators
By Robb William
- [11]. Pneumatic Controls , Author- Joji P.
- [12]. A Force-Controlled Pneumatic Actuator D. Ben-Dov and S. E. Salcudean

[13]. A High Performance Pneumatic Force Actuator System: Part I—Nonlinear Mathematical Model
By Edmond Richer Yildirim Hurmuzlu Southern Methodist University, School Of Engineering
And Applied Science, Mechanical Engineering Department,
Dallas, Tx 75275

[14]. Manual Page, Janatics India Ltd.,DS2 Compact Valve.

[15]. Robotic Gripper Sizing: The Science, Technology and LoreBy: Ted Zajac, Jr.

