



INTERNATIONAL JOURNAL OF CREATIVE RESEARCH THOUGHTS (IJCRT)

An International Open Access, Peer-reviewed, Refereed Journal

SOLAR POWERED DYNAMIC WIRELESS ELECTRIC VEHICLE CHARGING SYSTEM USING INDUCTIVE POWER TRANSFER TECHNOLOGY

Mr. Kunal Shirke¹,
Student, Department of
Electronics and
Telecommunications,
Ajeenkya DY Patil
School of Engineering,
Lohegaon, Pune.

Mr. Samarth Dyandyan²,
Student, Department of
Electronics and
Telecommunications,
Ajeenkya DY Patil School
of Engineering, Lohegaon,
Pune.

Mr. Aditya Chavan³,
Student, Department of
Electronics and
Telecommunications,
Ajeenkya DY Patil
School of Engineering,
Lohegaon, Pune.

Mr. Sagar D. Dhawale⁴,
Assistant Professor,
Department of
Electronics and
Telecommunication,
Ajeenkya DY Patil
School of Engineering,
Lohegaon, Pune.

ABSTRACT

With growing environmental concerns and the need for sustainable solutions in urban transport, electric vehicles (EVs) are becoming a more admired and environment-friendly alternative to cars that are powered by conventional fuel. Although, the adoption of EVs is still limited by challenges like range anxiety—drivers' concerns about running out of battery power on longer trips—and a lack of accessible charging stations, especially in cities. Addressing these issues requires innovative approaches that make EVs more convenient for everyday use while also supporting clean energy sources. This project proposes a solar-powered dynamic wireless charging (DWC) system for electric vehicles, using inductive power transfer (IPT) technology embedded in road infrastructure. The system enables EVs to charge continuously while driving, reducing range anxiety and improving charging accessibility by eliminating the need for frequent stops. By utilizing solar energy, this solution lessens the dependence on conventional power sources, promoting EV adoption as part of a greener transportation network. Working in collaboration with urban planners and engineers, the project aims to integrate this charging system directly into city roads, turning them into dynamic charging networks and contributing to reduced greenhouse gas emissions. This initiative envisions a future where electric vehicles can recharge seamlessly during travel, supporting a more sustainable and efficient urban transport system.

Keywords

Electric Vehicles (EVs), Dynamic Wireless Charging (DWC), Inductive Power Transfer (IPT), Wireless Power transfer (WPT), Electromagnetic Field

1. INTRODUCTION

The widespread use of ICE (Internal Combustion Engine) vehicles in transportation has led to harmful emissions, contributing to global warming and climate change. This has become a major concern worldwide. To lessen the dependency on traditional fuels and minimize their harmful impact on the nature, alternative solutions like electric vehicles (EVs) powered by renewable energy are gaining traction [1]. In recent years, both renewable energy and EVs have been widely adopted as concerns over global warming, pollution, and energy security continue to grow [7],[14],[21].

Wired charging electric vehicles have limited range and this is the biggest drawback of plug-in EVs [15],[17]. Wireless charging is an innovative technology that enables devices to be charged without physical connections by using electromagnetic induction. Dynamic wireless charging will reduce size of the battery and cost as well [22]. The concept of a Wireless Charging System (WCS) is based on mutual induction, a phenomenon, which Nikola Tesla introduced in 1887. It works by inducing an electromotive force (emf) in a receiver coil when a current flows through a nearby transmitter coil, effectively transferring energy without direct contact [8].

This technology is no longer limited to just consumer electronics—it's making its way into the automotive industry as well. Wireless charging for EVs allows drivers to charge their vehicles simply by parking over specially designed charging pads embedded in the ground. This eliminates the hassle of plugging in cables, which makes the process easy and user-friendly. Beyond transportation, wireless charging is also transforming other fields like healthcare, where medical implants and devices use it to eliminate the need for wires, reducing risks and improving practicality.

Dynamic Wireless Charging (DWC) is a thrilling technology that enables electric cars to charge on the move. In DWC, several transmitter pads are placed along the road and a receiver pad is fitted underneath the car at an ideal ground clearance. The fundamental building blocks of DWC are charging pads on the road and vehicle sides, a compensation network, and power modulators to manage energy transfer. This revolutionary technology can transform the adoption of electric vehicles by optimizing efficiency and ease, the direction towards a cleaner, more sustainable future [5].

2. PROPOSED SYSTEM

This section explains how the real life Implementation of the proposed Idea can be done.

A. *Power Generation Unit:* Power generation unit consists of solar panel, Battery for storage and DC – DC converter if needed. Solar panel will be installed on the side of roads or at suitable places like rooftops of the buildings and at suitable places battery will be installed to store the energy generated by the solar panels. If the voltage received from the solar panel unit is too high then DC-DC chopper/converter is used to lower the voltage as per need of battery. If the battery is rated 12 V but the voltage

supplied to it is 230V then the DC-DC converter will convert the 230V to 12V.

- B. *Inductive Power Transfer (IPT) Mechanism:* The system includes multiple charging coils installed in the road and a receiving coil placed at the bottom of the vehicle. When the vehicle passes over the charging area, power is transferred wirelessly using high-frequency alternating current (AC)[17]. DC -AC conversion will be needed before supplying current to a coil from DC source like a battery. Transformer may be needed if the required voltage is high or low (step up or step down).
- C. *Power Receiving Unit:* Power receiving unit consists of receiving coil and battery for power storage. This unit will be embedded on the electric vehicle. Once the Rx coil gets aligned with the transmitter coil, due to electromagnetic induction the power transfer will happen , the AC current will get induced into the receiving coil then it will be converted to DC by AC-DC converter (rectifier) to feed the battery.
- D. *Power Management and Control:* A power control system regulates energy flow between the solar panels and the wireless charging coils. Smart controllers optimize energy use and ensure safe charging with minimal energy loss.

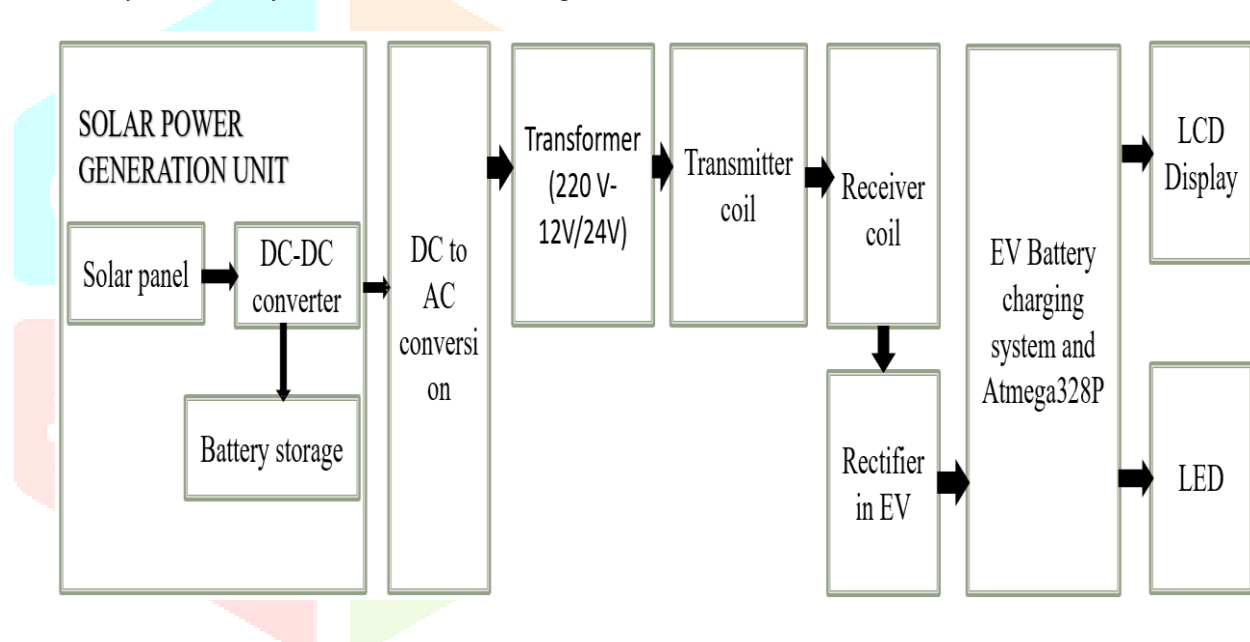

Fig. 1 Block Diagram of Solar Powered Dynamic wireless electric vehicle charging System Using Inductive power transfer Technology

3. METHODOLOGY

All The methodology involves designing, simulating, and testing the proposed solar-powered inductive charging system. The approach includes:

A. *Implementation:*

- 1) *Power Generation:* 10 W solar panel is used to generate the power / current, the 12V, 8Ah battery is used to store the energy. The power from the battery is supplied to xkt412 circuit which acts like DC/AC inverter and converts the DC i/p current to AC output to supply it to the transmitter coil.
- 2) *Power transfer:* The high frequency alternating current supply provided by xkt412 is fed to transmitter coil, alternating current in the transmitter coil generates the EM(electromagnetic field) around the coil.
- 3) *Power Reception and storage:* Once the receiver coil embedded on the electric vehicle comes in proximity of/aligns with the transmitter coil the current gets induced in the receiver coil due to electromagnetic

induction. Then the AC current from receiver coil is converted to DC to feed it up to the battery on the electric vehicle.

- 4) *Control unit:* The Atmega328P controller controls the charging of the battery, onboard display and various

other components like INA219 voltage and current sensor. Display shows the voltage received by battery.

B. *System Design:*

The main goal of a DWC (dynamic wireless charging) system is to ensure that vehicle receives more power than it consumes while driving. Key challenges include managing power delivery, handling vehicle speed variations, and reducing misalignment issues that can affect charging efficiency [5]. Developing a circuit model incorporating solar PV panels, an MPPT-controlled boost converter, an IPT system (inductive power transfer), and battery of electric vehicle charging unit.

Wireless charging is based on the law of Faraday that change in the magnetic field induces an electric current in the receiving coil [10]. It can be represented by the given formula

$$\oint \mathbf{B} \cdot d\mathbf{s} = \mu_0 I N_1 \quad (\mu_0 = 4\pi \times 10^{-7} \text{H/m})$$

$$E = -N_2 d\Phi / dt$$

The negative sign ensures that the direction of the induced current (given by N_2 , the number of turns in the coil) opposes the change in flux.

where B is magnetic flux density, μ_0 is vacuum magnetic permeability, N_1 represents primary turns/coil, N_2 represents secondary coil, Φ is magnetic flux and E denotes EMF (Induced Electromotive Force), I is current.

These are necessary equation kept in mind while designing the transmitting and receiving coil.

C. *Prototype Testing:* Constructing a scaled-down model with transmitter and receiver coils to measure real-time charging performance.

D. *Performance Metrics:* Evaluating efficiency, energy transfer rates, and system stability under different operating conditions.

4. RESULTS

Increase in the distance reduces the power transfer efficiency, it is true for both horizontal and vertical distances, Table 1 Shows the corresponding Voltage with distance.

TABLE 1

CHANGE IN VOLTAGE WITH CHANGE IN DISTANCE

Sr.No.	Vertical Distance/Air gap	Voltage Received by Receiver Coil
1.	11 mm	~4.9V
2.	8-9 mm	~6.7 V
3.	6-7mm	~9.1 V
4.	5 mm	~12.7 V

Fig.2 shows the above data in graphical format to understand the efficiency of the system

From the graph and Table we can safely say that with increase in Distance the efficiency of the system / Power transfer reduces, to counter this disadvantage we can introduce several transmitter and receiver coils furthermore we can adjust the structures of the transmitter coil and receiver coil to render them more acceptable to misalignment.

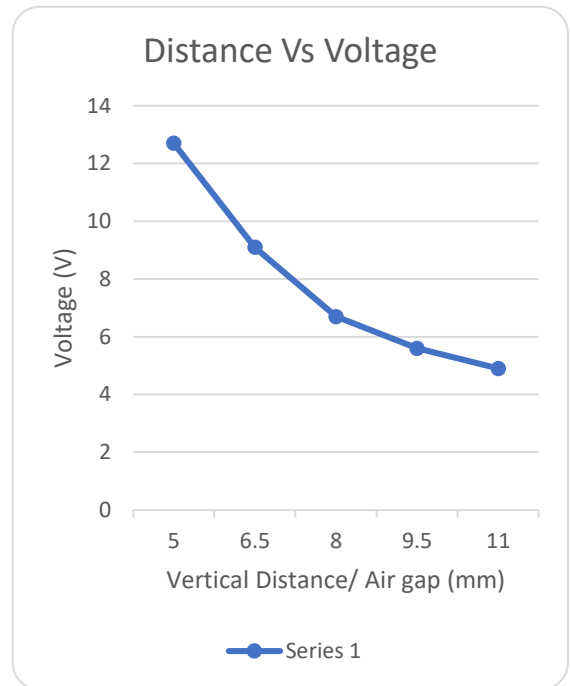

Fig. 2 A Distance (mm) Vs Voltage (V) Graph

Below fig.3 and fig.4 shows the Prototype of DWC system, where there is the power generation unit consists of Solar panel and Battery and the Power Receiving unit with power control unit consists of Atmega328 P controller and receiving coil and Li-Ion battery on vehicle.

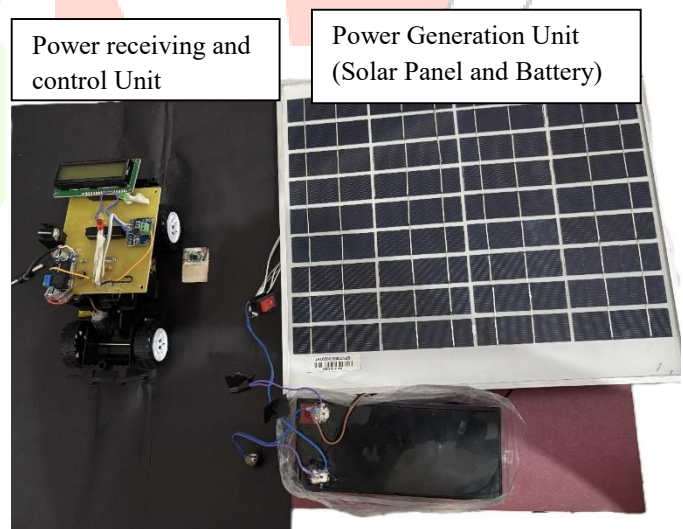

Fig. 3 prototype of DWC System

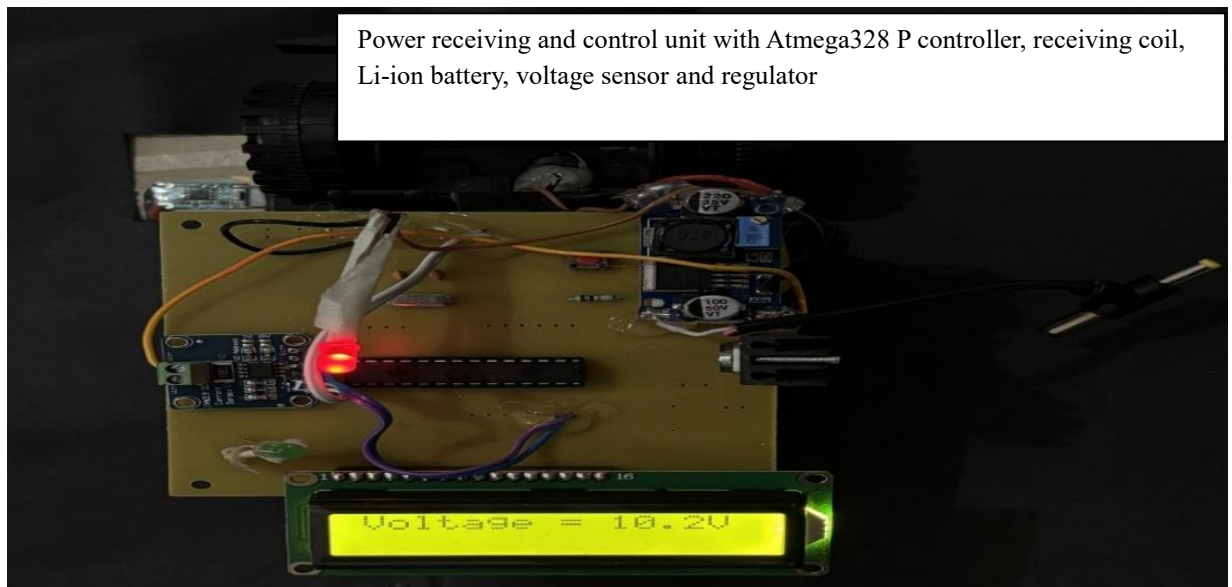

Fig. 4 Power receiving and control unit

Fig.5 shows the transmitting pad with xkt412 circuit, law introduced by Faraday states that changing magnetic field induces current in receiving coil, for obtaining the varying magnetic field we need alternating (AC) current, the

xkt412 circuit converts the DC current from battery into AC current to provide it to transmitting coils.

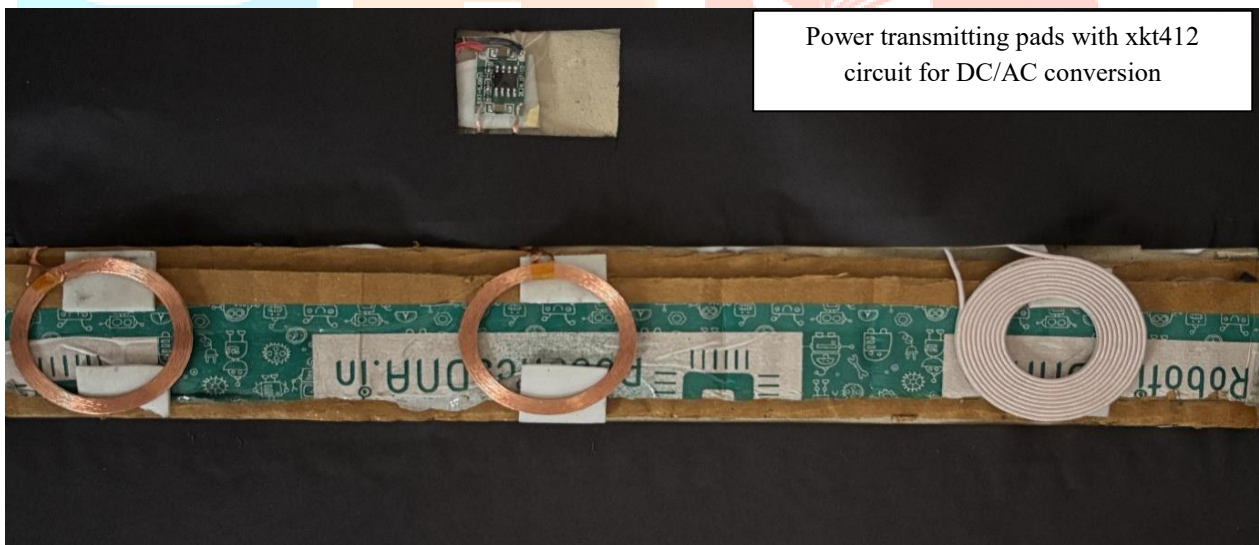

Fig. 5 Power transmitting pads

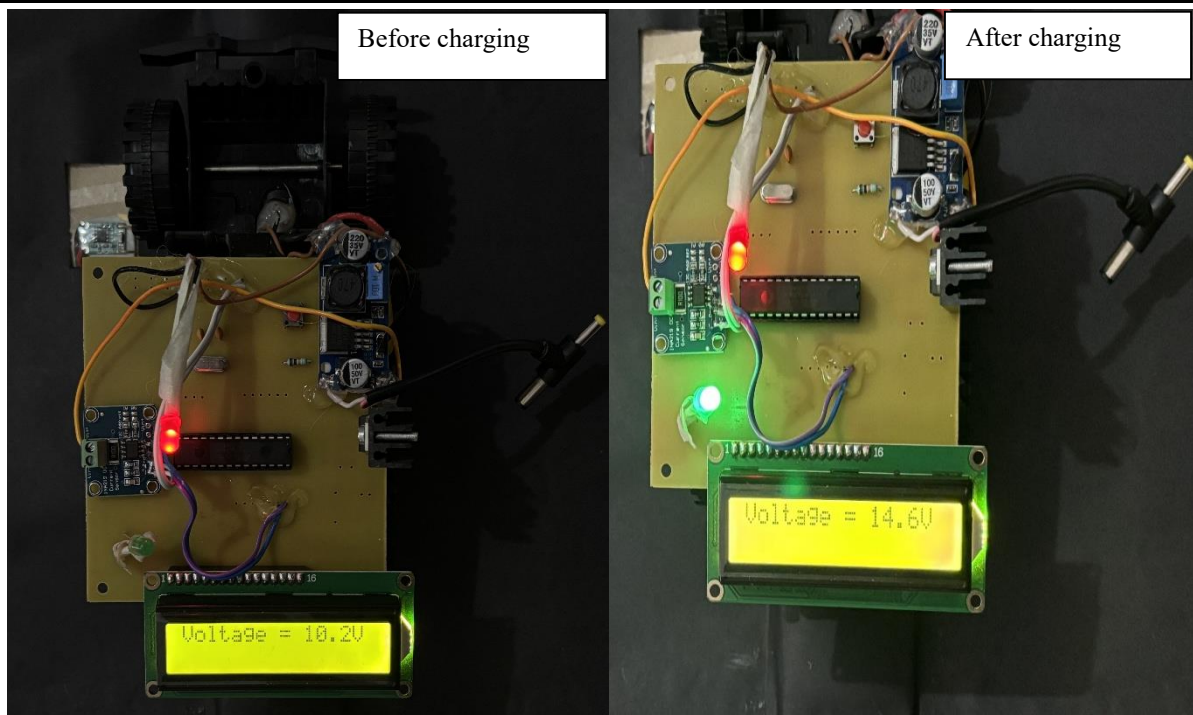

Fig. 6 Display showing before and after charging state of battery

We have utilized a 10 W, 18V rated solar panel. The battery is 12V and 8Ah capacity rated. The power supplied by solar panel can be calculated using formula:

$$P = V \times I$$

where P = Power, V = voltage supplied and I = current. To find out the current supplied by the solar panel we can re-write the equation as:

$$I = \frac{P}{V} = \frac{10W}{18V} = 0.5555A$$

Charging time for battery (connected to solar panel) can be determined as:

$$\text{Charging Time } T = \frac{\text{Battery Capacity}}{\text{Current supplied by solar panel}} = \frac{8Ah}{0.5555A} = 14.04 h \approx 14h$$

The approximate time required for charging the battery is 14 hours.

5. CONCLUSIONS

This paper proposed a solar-powered wireless charging system that allows EVs to charge while moving. The integration of renewable energy and IPT technology enhances sustainability and eliminates the need for large onboard batteries. Data suggests that increase in air gap decreases the power transfer however it can be compensated by designing the coil that can have more tolerance against the misalignment. Further research is recommended to optimize coil alignment and energy management strategies to improve overall performance.

6. ACKNOWLEDGEMENT

We are truly grateful to the Head of the Electronics & Telecommunication Engineering Department for giving us the opportunity to work on this project. Our heartfelt thanks go to our guide for his invaluable support, insightful

suggestions, and continuous encouragement, without which this work would not have been possible. We deeply appreciate his timely guidance, which played a crucial role in helping us complete this project successfully within the given timeframe.

7. REFERENCES

- [1]. A. Mahesh, B. Chokkalingam and L. Mihet-Popa, "Inductive Wireless Power Transfer Charging for Electric Vehicles—A Review," in *IEEE Access*, vol. 9, pp. 137667-137713, 2021, doi: 10.1109/ACCESS.2021.3116678.
- [2]. N. Mohamed et al., "A Comprehensive Analysis of Wireless Charging Systems for Electric Vehicles," in *IEEE Access*, vol. 10, pp. 43865-43881, 2022, doi: 10.1109/ACCESS.2022.3168727.
- [3]. V. Ramakrishnan et al., "A Comprehensive Review on Efficiency Enhancement of Wireless Charging System for the Electric Vehicles Applications," in *IEEE Access*, vol. 12, pp. 46967-46994, 2024, doi: 10.1109/ACCESS.2024.3378303.
- [4]. I. Casauco Tenllado, A. Triviño Cabrera and Z. Lin, "Simultaneous Wireless Power and Data Transfer for Electric Vehicle Charging: A Review," in *IEEE Transactions on Transportation Electrification*, vol. 10, no. 2, pp. 4542-4570, June 2024, doi: 10.1109/TTE.2023.3309505.
- [5]. Y. Shanmugam et al., "A Systematic Review of Dynamic Wireless Charging System for Electric Transportation," in *IEEE Access*, vol. 10, pp. 133617-133642, 2022, doi: 10.1109/ACCESS.2022.3227217.
- [6]. J. Rahulkumar. et al., "An Empirical Survey on Wireless Inductive Power Pad and Resonant Magnetic Field Coupling for In-Motion EV Charging System," in *IEEE Access*, vol. 11, pp. 4660-4693, 2023, doi: 10.1109/ACCESS.2022.3232852.

- [7]. X. Mou, Y. Zhang, J. Jiang and H. Sun, "Achieving Low Carbon Emission for Dynamically Charging Electric Vehicles Through Renewable Energy Integration," in IEEE Access, vol. 7, pp. 118876-118888, 2019, doi: 10.1109/ACCESS.2019.2936935.
- [8]. M. R. R. Razu et al., "Wireless Charging of Electric Vehicle While Driving," in IEEE Access, vol. 9, pp. 157973-157983, 2021, doi: 10.1109/ACCESS.2021.3130099.
- [9]. A. Triviño, J. Sánchez and A. Delgado, "Efficient Methodology of the Coil Design for a Dynamic Wireless Charger," in IEEE Access, vol. 10, pp. 83368-83378, 2022, doi: 10.1109/ACCESS.2022.3196023.
- [10]. A. Sagar et al., "A Comprehensive Review of the Recent Development of Wireless Power Transfer Technologies for Electric Vehicle Charging Systems," in IEEE Access, vol. 11, pp. 83703-83751, 2023, doi: 10.1109/ACCESS.2023.3300475.
- [11]. K. Kumar, Z. S. L. Albulushi, and A. . Shil, "Solar Wireless EV Charging System", *J Stud Res*, May 2023.
- [12]. X. Wu, G. Li and J. Zhou, "A Lightweight Secure Management Scheme for Energy Harvesting Dynamic Wireless Charging System," in IEEE Access, vol. 8, pp. 224729-224740, 2020, doi: 10.1109/ACCESS.2020.3044293.
- [13]. E. ElGhanam, H. Sharf, Y. Odeh, M. S. Hassan and A. H. Osman, "On the Coordination of Charging Demand of Electric Vehicles in a Network of Dynamic Wireless Charging Systems," in IEEE Access, vol. 10, pp. 62879-62892, 2022, doi: 10.1109/ACCESS.2022.3182700.
- [14]. A. O. Elmeligy, E. Elghanam, M. S. Hassan, A. H. Osman, A. A. Shalaby and M. Shaaban, "Optimal Planning of Dynamic Wireless Charging Infrastructure for Electric Vehicles," in IEEE Access, vol. 12, pp. 30661-30673, 2024, doi: 10.1109/ACCESS.2024.3365636.
- [15]. A. Fathollahi, S. Y. Derakhshandeh, A. Ghiasian and M. A. S. Masoum, "Optimal Siting and Sizing of Wireless EV Charging Infrastructures Considering Traffic Network and Power Distribution System," in IEEE Access, vol. 10, pp. 117105-117117, 2022, doi: 10.1109/ACCESS.2022.3219055.
- [16]. M. Behnamfar, T. O. Olowu, M. Tariq and A. Sarwat, "Comprehensive Review on Power Pulsation in Dynamic Wireless Charging of Electric Vehicles," in IEEE Access, vol. 12, pp. 66858-66882, 2024, doi: 10.1109/ACCESS.2024.3397583.
- [17]. A. Mahesh, B. Chokkalingam, R. Verma and L. Mihet-Popa, "Load Invariant CC and CV Modes for Static/Dynamic Wireless Charging System With Half-Bridge Multi-Leg Converter Topology," in IEEE Access, vol. 13, pp. 9654-9665, 2025, doi: 10.1109/ACCESS.2025.3526654.
- [18]. L. Zhong, H. S. En, M. Pei, J. Xiong and T. Wang, "Optimized Speed Control for Electric Vehicles on Dynamic Wireless Charging Lanes: An Eco-Driving Approach," in *Journal of Intelligent and Connected Vehicles*, vol. 7, no. 1, pp. 52-63, March 2024, doi: 10.26599/JICV.2023.9210033.
- [19]. L. Tan, W. Zhao, H. Liu, J. Li and X. Huang, "Design and Optimization of Ground-Side Power Transmitting Coil Parameters for EV Dynamic Wireless Charging System," in IEEE Access, vol. 8, pp. 74595-74604, 2020, doi: 10.1109/ACCESS.2020.2988622.
- [20]. I. Hwang, Y. J. Jang, Y. D. Ko and M. S. Lee, "System Optimization for Dynamic Wireless Charging Electric Vehicles Operating in a Multiple-Route Environment," in IEEE Transactions on Intelligent Transportation Systems, vol. 19, no. 6, pp. 1709-1726, June 2018, doi: 10.1109/TITS.2017.2731787.
- [21]. L. Geng, C. Sun, D. Song, S. Yang, Y. Ma and Z. Lu, "Distributed Collaborative Optimization of Integrated Transportation-Power Energy Systems Considering Dynamic Wireless Charging," in IEEE Access, vol. 12, pp. 121416-121432, 2024, doi: 10.1109/ACCESS.2024.3452504.
- [22]. X. Mou, Y. Zhang, J. Jiang and H. Sun, "Achieving Low Carbon Emission for Dynamically Charging Electric Vehicles Through Renewable Energy Integration," in IEEE Access, vol. 7, pp. 118876-118888, 2019, doi: 10.1109/ACCESS.2019.2936935.
- [23]. X. Ren, C. S. Lai, Z. Guo and G. Taylor, "Eco-Driving With Partial Wireless Charging Lane at Signalized Intersection: A Reinforcement Learning Approach," in IEEE Transactions on Consumer Electronics, vol. 70, no. 4, pp. 6547-6559, Nov. 2024, doi: 10.1109/TCE.2024.3482101.
- [24]. A. Triviño, J. Sánchez and A. Delgado, "Efficient Methodology of the Coil Design for a Dynamic Wireless Charger," in IEEE Access, vol. 10, pp. 83368-83378, 2022, doi: 10.1109/ACCESS.2022.3196023.
- [25]. S. A. Moosavi, S. S. Mortazavi, A. Namadmalan, A. Iqbal and M. Al-Hitmi, "Design and Sensitivity Analysis of Dynamic Wireless Chargers for Efficient Energy Transfer," in IEEE Access, vol. 9, pp. 16286-16295, 2021, doi: 10.1109/ACCESS.2020.3048029