



# Design and development of an intelligent automatic door opening system using rack and pinion mechanism

Nikhil Kumar<sup>1</sup>, Ritik Raushan<sup>2</sup>, Rajnish Kumar<sup>3</sup>, Shankar Kumar<sup>4</sup>, MD Ishtiaque Zafar<sup>5</sup>, Dinesh Kumar<sup>6,\*</sup>

<sup>1, 2, 3, 4</sup>Student, <sup>5, 6</sup>Lecturer

<sup>1, 2, 3, 4, 5</sup>Department of Mechanical Engineering, Government Polytechnic, Nawada - 805114 (Bihar) India (DSTTE Govt. of Bihar)

<sup>6</sup>Department of Science and Humanity, Government Polytechnic, Nawada - 805114 (Bihar) India (DSTTE Govt. of Bihar)

**Abstract:** This paper presents the design of an automatic door system using a rack and pinion mechanism for contactless operation. The system aims to reduce human effort, improve hygiene, and provide convenience, especially for elderly and physically challenged individuals. An ultrasonic sensor (HC-SR04) detects the presence of a person and sends signals to the Arduino UNO, which acts as the control unit. Based on the input, the Arduino controls the motor driver (L298N) to operate a DC gear motor. The motor's rotational motion is converted into linear motion through the rack and pinion mechanism, enabling automatic door opening. When no object is detected, the system reverses the motor to close the door. The system is simple, cost-effective, reliable, and suitable for use in homes, offices, hospitals, and public places, demonstrating the practical application of automation in daily life.

**Index Terms** - Arduino UNO, Ultrasonic Sensor, DC Motor, Rack and Pinion Mechanism.

## I. INTRODUCTION

In today's modern world, automation is becoming very important in our daily life. Many systems in homes, hospitals, offices, and industries are now automatic. One such useful system is an automatic door system, which helps people to open and close doors without any physical effort. In old or traditional systems, doors are opened manually. This takes time and also requires touching the door. In public places, many people touch the same door, which is not good for hygiene and can spread germs and infections. Also, elderly people and physically challenged persons face difficulty in using manual doors. To solve these problems, we use an automatic door system. This system works using sensor, controller, and motor. We use an ultrasonic sensor (HC-SR04) to detect a person. When a person comes near the door, the sensor sends a signal to the Arduino UNO, which is the main control unit. The Arduino gives command to the motor driver (L298N), which controls the DC gear motor. The motor produces rotational motion, which is converted into linear motion using a rack and pinion mechanism. This motion helps to open the door automatically. After some time, when no person is detected, the door closes automatically. The main objective of this paper is to make a simple, low-cost, and efficient system. This works improves safety, hygiene, and convenience. It also shows how basic technology can be used in real life to solve problems easily.

The development of modern engineering systems is the result of contributions from various inventors over different periods. The rack and pinion mechanism, an important mechanical system used to convert rotational motion into linear motion, was conceptualized by Leonardo da Vinci in the 15th century. In electrical engineering, the development of the DC motor is based on the work of Michael Faraday around 1821, who demonstrated the principle of electromagnetic rotation, forming the foundation of modern motors. The concept of the ultrasonic sensor originates from SONAR technology, first used during World War I in the 1910s for detecting underwater objects. This principle is now widely used in distance measurement and automation systems. In modern electronics, the Arduino UNO, developed by Massimo Banzi and his team around 2005, has made embedded system design simple and accessible. Additionally, the L298N motor driver, developed by STMicroelectronics in the 1980s, enables efficient control of motor speed and direction. Together, these inventions show the evolution of technology from basic mechanical designs to advanced electronic systems used in modern automation and robotics.

## 1.2 Problem Statement

In many places, doors are still operated manually, which creates several problems in daily life. Manual door operation requires physical effort and direct human contact, which makes it inconvenient, especially in crowded areas. In public places such as hospitals, offices, and shopping malls, many people use the same door repeatedly, which increases the risk of spreading germs and infections. This creates serious hygiene concerns in modern environments. In addition, manual doors are not user-friendly for elderly and physically challenged individuals, as they may find it difficult to open and close doors frequently. It also consumes time and reduces efficiency in places where smooth and fast movement of people is required. Moreover, traditional door systems are not suitable for modern smart infrastructure, where automation plays an important role. Therefore, there is a need for an efficient, reliable, and contactless door system that can overcome these problems and provide a better solution for modern applications.

## 1.3. Components used

This is main component to design structure of the proposed work. These components are given in following subsections.

### 1.3.1 Ultrasonic sensor

An ultrasonic sensor (figure 1) is used to measure the distance of an object using sound waves. It sends ultrasonic pulses and receives the reflected signal to calculate distance. It provides higher accuracy compared to IR sensors and is widely used in automation systems like automatic doors, obstacle detection, robotics etc.

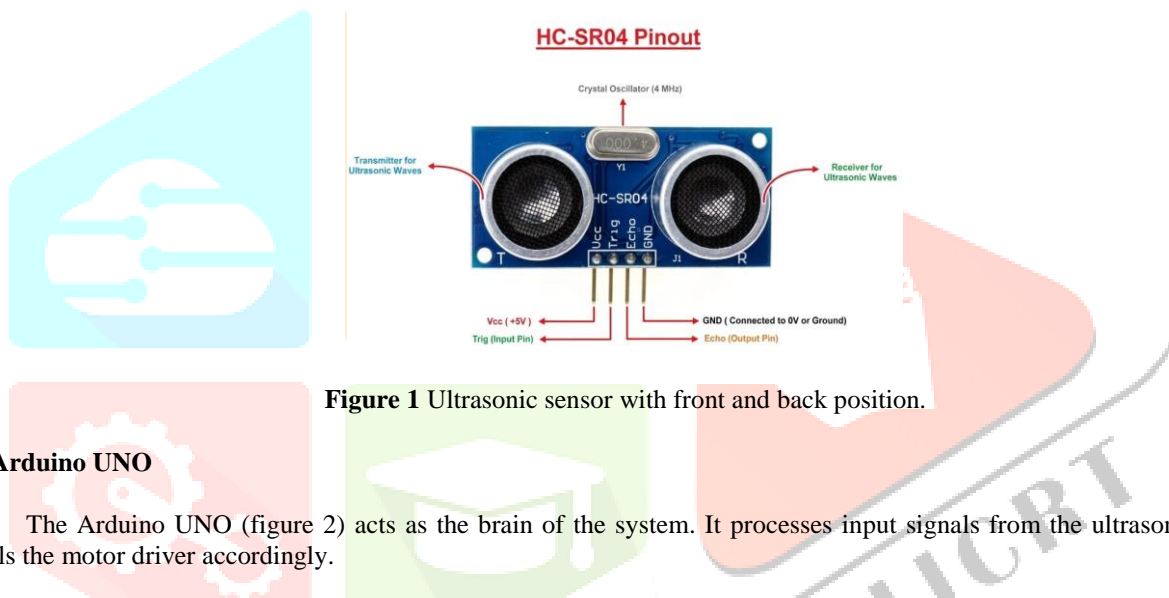

Figure 1 Ultrasonic sensor with front and back position.

### 1.3.2 Arduino UNO

The Arduino UNO (figure 2) acts as the brain of the system. It processes input signals from the ultrasonic sensor and controls the motor driver accordingly.

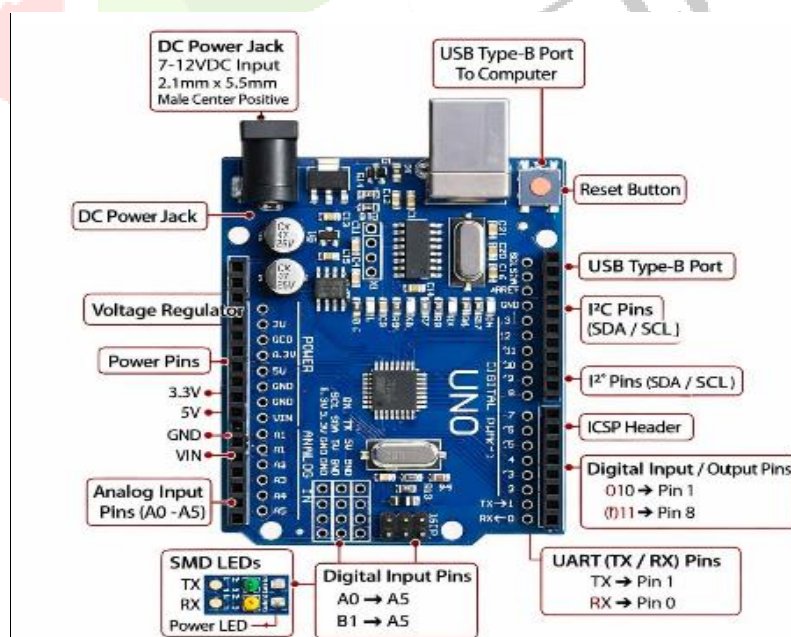

Figure 2 Basic structure of Arduino UNO.

### 1.3.3 DC Motor

A DC motor is an electrical device that converts electrical energy into mechanical motion (see in figure 3). It operates on the principle of electromagnetic force and is commonly used to produce rotational movement. In automated systems, it is used to drive mechanisms such as opening and closing doors, moving parts, and operating machinery efficiently.

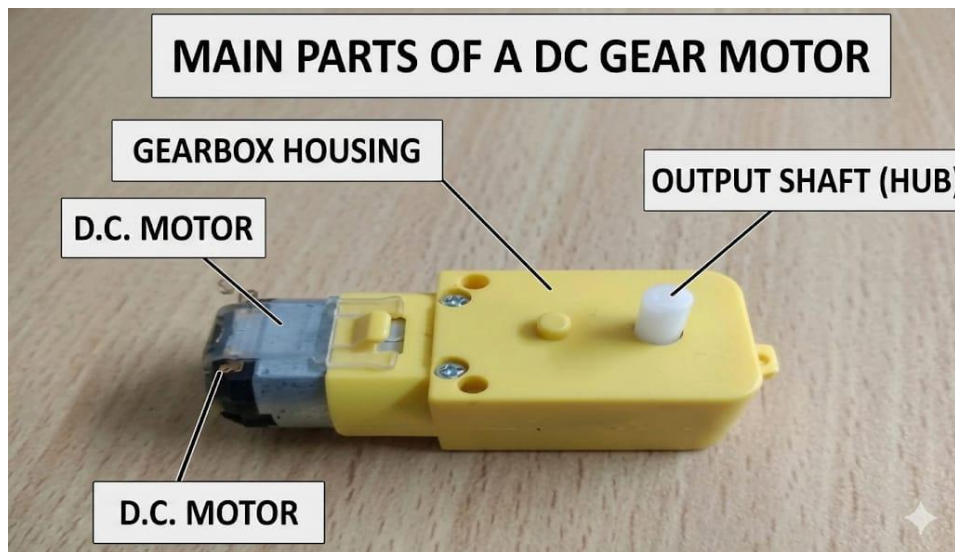

Figure 3 DC gear motor with their components.

### 1.3.4 Motor Driver

Motor Driver (L293D / L298N) is a device that controls the direction and speed of the motor by receiving signals from the microcontroller and supplying appropriate power to the motor (see in figure 4).

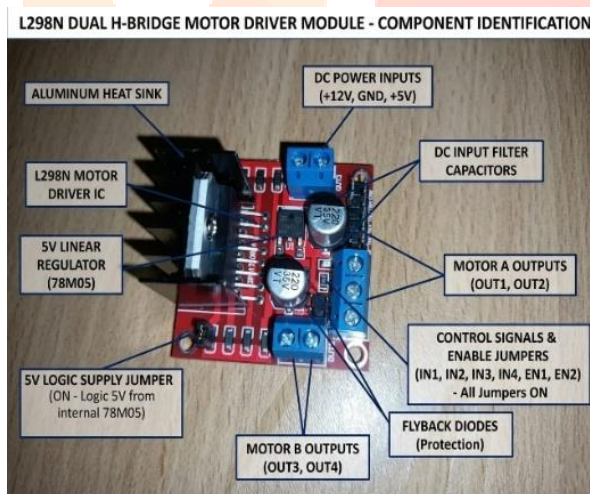

Figure 4 Actual structure of motor drive (L293D/L298N).

### 1.3.5 Power Adaptor

A power supply provides the required electrical energy to operate all components of the system (see in figure 5).



Figure 5 Use power adaptor (9v output) in this work.

### 1.3.6 Connecting Wires

Connecting wires are used to establish electrical connections between different components in the circuit (see figure 6).



**Figure 6** Use jumping wires in this work.

### 1.3.7 Rack and Pinion

A rack and pinion is a type of mechanical system used to convert rotational motion into linear motion. It consists of a circular gear (pinion) and a straight toothed gear (rack) (see in 7). When the pinion rotates, it moves the rack in a straight line, which helps in opening and closing the door.

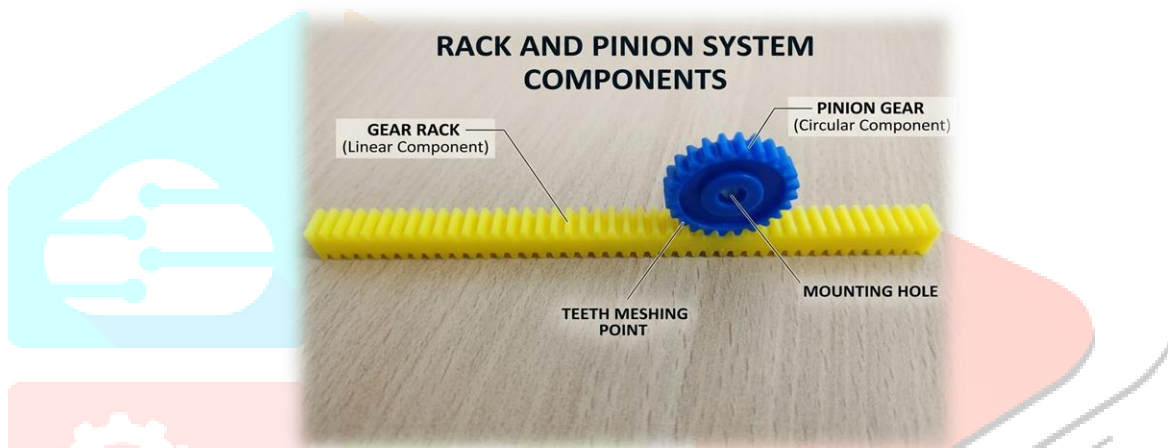

**Figure 7** Combination of rack and pinion components is used.

## I. LITERATURE REVIEW

Automatic door systems have developed significantly over time to improve convenience, safety, and hygiene. In earlier times, doors were operated manually, which required physical effort and direct human contact. This created inconvenience in crowded places and increased the risk of spreading germs, especially in hospitals and public areas. Basic mechanical systems such as hinged and sliding doors were initially used. The principles of motion conversion, including rack and pinion mechanisms, are well explained in standard design books by Khurmi and Gupta (2006) [1] and Bhandari (2009) [2]. These mechanisms provide a simple and effective way to convert rotational motion into linear motion. Later, sensor-based automatic door systems were introduced.

Oladumoye et al. (2014) [3] developed an automatic door using IR sensors. Although it provided automation, it had limitations such as low accuracy and false detection. With the growth of smart infrastructure, automation in buildings increased, as discussed by Smith (2015) [4], highlighting the importance of contactless systems. Further improvements were made by Chomo et al. (2018) [5], who focused on developing reliable automatic door systems using better control techniques. Kumar (2019) [6] emphasized the role of sensor-based control systems and microcontrollers in improving system performance and efficiency. In recent years, ultrasonic sensors have gained importance due to their higher accuracy in distance measurement. Lee (2021) [7] explained that ultrasonic sensors perform better than IR sensors in different environmental conditions. Additionally, Patel (2022) [8] discussed IoT-based automation systems, which provide advanced control but increase system complexity and cost. Jimoh and Aliu (2023) [9] developed an intelligent automatic door system with improved safety and efficiency using modern embedded systems.

Arduino Official Documentation (2026) [10] also provides detailed information about integrating ultrasonic sensors and motor drivers for automation applications. Based on these studies, the proposed work uses an ultrasonic sensor with Arduino UNO and a rack and pinion mechanism to develop a low-cost, accurate, and efficient automatic door system. Compared to previous systems, it provides better precision, smooth operation, and reduced maintenance, making it suitable for real-life applications.

## II. METHODOLOGY

In this paper, the main focus is on component connection, calculation, and coding. All parts are connected properly so that the system works smoothly (see in figure 8). These are given in following subsection.

### 3.1 Components Connection Ultrasonic Sensor → Arduino

- VCC → 5V
- GND → GND
- TRIG → Pin 11
- ECHO → Pin 12
- Arduino → Motor Driver (L298N)
- IN1 → Pin 9
- IN2 → Pin 10
- ENA → Pin 5 (PWM)
- GND → Common Ground
- Motor Driver → DC Motor
- Output pins → Motor terminals

### 3.2 WORKING LOGIC

Ultrasonic sensor continuously measures distance, if object is detected between 0 to 4 cm, system activates Arduino sends signal to motor driver then motor rotates → door opens; after delay → motor reverses → door closes.

### 3.3 Motor Control Logic

IN1 HIGH, IN2 LOW → Forward (Opening) IN1 LOW, IN2 HIGH → Reverse (Closing) PWM (ENA) controls speed.

### 3.4 Timing Control

Opening Time → 1 second Hold Time → 3 seconds Closing Time → 1 second.

### 3.5 Mechanical Operation

Motor rotation → Pinion gear → Rack movement → Door slides linearly.

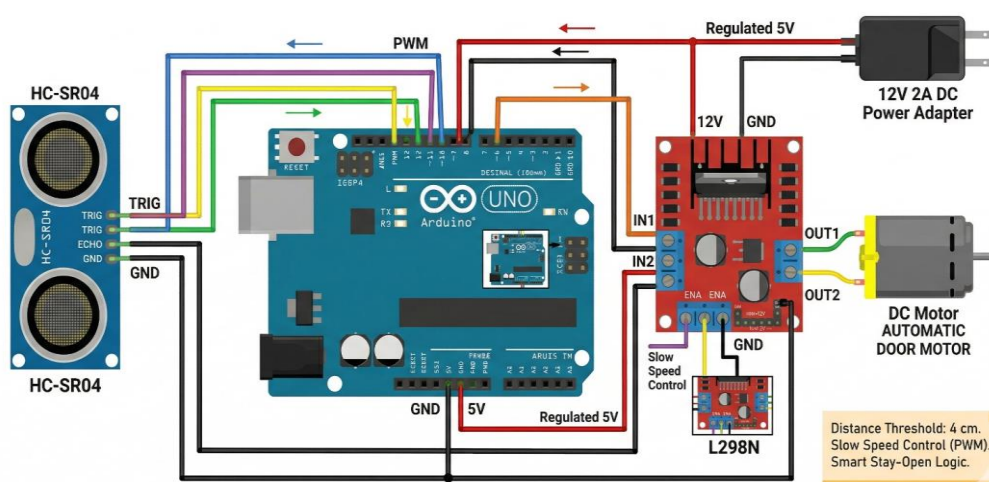

**Figure 8** Circuit diagram: Automatic door control system.

### 3.6 Calculation (Motor Speed & Gear)

The assume data for our proposed problem is considered as width, weight and travel distance of the door are 0.5 cm, 0.73575 N and 10 cm respectively. Pinion gear diameter ( $D$ ) is 3 cm and speed of the motor is 60 RPM.

### 3.6.1 Rack and Pinion Relationship

The formula of Circumference ( $C$ ) of pinion is given as

$$C = \pi \times D \text{ unit.}$$

$$\Rightarrow C = 3.14 \times 3 = 9.42 \text{ cm.}$$

Here, we understand that when the pinion gear completes one revolution then the rack gear will move 9.42 cm.

### 3.6.2 Required Door Travel

Given travel required to fully open the door = 10 cm

$$\text{Required revolutions (N)} = \frac{\text{Travel required to fully open the door}}{C} = \frac{10}{9.42} = 1.061 \approx 1.$$

This implies that the pinion needs to rotate approximately 1 turns to fully open the door.

### 3.6.3 Time to open Door

Speed of motor = 60 RPM and this is converted into RPS which is given as

$$\text{Speed of motor} = \frac{60}{60} = 1 \text{ RPS.}$$

Then the time taken to open the door, *i.e.*,

$$t = \frac{\text{Required revolutions (N)}}{\text{Speed of motor in RPS}} = \frac{1}{1} = 1 \text{ sec.}$$

Thus, the door will open in a short time 1 second.

### 3.6.4 Torque Requirement

$$\text{Door weight (Force)} = 0.73575 \text{ N,}$$

$$\text{Pinion radius (r)} = \frac{3}{2} = 1.5 \text{ cm} = 0.015 \text{ m,}$$

$$\text{Torque } (\tau) = \text{Force} \times r,$$

$$\tau = 0.73575 \times 0.015 = 0.011 \text{ N m.}$$

The above torque is calculated as without friction. So for reality in this process friction is also involved. For the real torque ( $\tau_R$ ) is expressed as

$$\tau_R = 2 \times \tau$$

$$\Rightarrow \tau_R = 2 \times 0.011 = 0.022 \text{ N m.}$$

### 3.7 Simple Arduino Coding

Sensor measures distance when an object presents in front of the door. If distance is less than 4 cm then door will open and it will remain open approx. 7 seconds according our coding set in Arduino. If object is available or not available near to the door then door will be closed automatically after 7 seconds. Code controls the direction of motor using IN1 and IN2 pins. The complete code of Arduino for coming 5 years is give as below:

```
// --- 5-YEAR AUTONOMOUS GATE SYSTEM (4CM THRESHOLD) ---
// Pins: Trig=11, Echo=12, ENA=5 (PWM), IN1=9, IN2=10

const int trigPin = 11;
const int echoPin = 12;
const int enaPin = 5; // PWM Pin for slow speed
const int in1 = 9;
const int in2 = 10;

// Motor Speed (0-255). 160 is smooth.
int slowSpeed = 160;
void setup() {
  pinMode(trigPin, OUTPUT);
  pinMode(echoPin, INPUT);
  pinMode(enaPin, OUTPUT);
  pinMode(in1, OUTPUT);
  pinMode(in2, OUTPUT);

// Initial State: Gate Stopped
  digitalWrite(in1, LOW);
  digitalWrite(in2, LOW);
  analogWrite(enaPin, 0);

  void loop() {
    long duration;
```

```

int distance;

// 1. Precise Sensor Pulse
digitalWrite(trigPin, LOW);
delayMicroseconds(2);
digitalWrite(trigPin, HIGH);
delayMicroseconds(10);
digitalWrite(trigPin, LOW);

// 2. Reading Distance
duration = pulseIn(echoPin, HIGH, 30000);
distance = duration * 0.034 / 2;

// 3. AUTOMATIC LOGIC (Threshold: 4 cm)
// Distance 1cm se 4cm ke beech ho tabhi chalega
if (distance > 1 && distance <= 4) {
// --- STEP 1: SLOW OPENING (1 SECOND) ---
analogWrite(enaPin, slowSpeed);
digitalWrite(in1, HIGH);
digitalWrite(in2, LOW);
delay(1000);

// --- STEP 2: HOLD (Wait) ---
digitalWrite(in1, LOW);
digitalWrite(in2, LOW);
delay(3000); // Door stays open for 3 seconds

// --- STEP 3: SLOW CLOSING (1 SECOND) ---
analogWrite(enaPin, slowSpeed);
digitalWrite(in1, LOW);
digitalWrite(in2, HIGH);
delay(1000);

// --- STEP 4: FULL STOP ---
digitalWrite(in1, LOW);
digitalWrite(in2, LOW);
analogWrite(enaPin, 0);

// Recovery gap taaki gate loop mein na phanse
delay(2000);
// Processor Stability Delay
delay(50);

```

### 3.8 Fabrication & Testing

- Frame is made using metal structure.
- Rack is fixed on door and aligned properly with pinion.
- Motor is mounted firmly to avoid vibration, after assembly, testing is done for:
  - Opening time
  - Closing time
  - Smooth motion
  - Sensor accuracy.

This method shows how sensor → Arduino → motor driver → motor → rack & pinion work together. The system is simple, efficient, and automatic, with proper calculation and coding for smooth operation.

## IV. WORKING PRINCIPLE

The operational logic of the Intelligent Automatic Door Opening System is centered around the seamless integration of electronic sensing and mechanical actuation. The process begins with the Ultrasonic sensor (HC-SR04), which acts as the eyes of the system by continuously emitting high-frequency sound waves into the surrounding environment. When these waves encounter an object or a person within a predefined range, they bounce back to the sensor, allowing the Arduino UNO microcontroller to calculate the exact distance based on the time interval of the reflected signal.

Once the Arduino confirms that a person is approaching the entrance, it executes a programmed command to trigger the L298N motor driver. This driver serves as a bridge, providing the necessary current to the DC gear motor while protecting the microcontroller from power surges. As the motor begins to rotate, its torque is transmitted directly to the pinion gear. This is where the core mechanical conversion happens: the rotating pinion meshes with the stationary rack fixed to the door panel,

effectively transforming rotational motion into smooth linear displacement. Consequently, the door slides open without any manual intervention.

To ensure energy efficiency and safety, the system incorporates specific delay-time logic. After the person has passed through the entryway and the sensor no longer detects any obstruction, the Arduino waits for a set duration—typically four seconds—before initiating the closing sequence. It then sends a reverse polarity signal to the motor driver, causing the DC motor to spin in the opposite direction. The rack and pinion mechanism then pulls the door back to its original closed position. This entire cycle is designed to be repetitive and autonomous, providing a hands-free, hygienic, and modern solution for building access.

## V. BLOCK DIAGRAM AND SYSTEM ARCHITECTURE

The system architecture of the Intelligent Automatic Door follows a linear signal processing flow to ensure real-time response and high operational efficiency. As shown in the block diagram in figure 9, the process is initiated by the Ultrasonic Sensor (HC-SR04), which serves as the primary input device for detecting human presence within the sensor's range. This input signal is then transmitted to the Arduino UNO, the central processing unit, where the distance data is analyzed against the programmed threshold values.

Upon successful validation of the trigger distance, the Arduino communicates with the L298N Motor Driver, which acts as an intermediate to regulate the power flow from the battery source to the actuator. The DC Gear Motor then receives the electrical energy and converts it into mechanical rotation. This torque is finally applied to the Rack and Pinion mechanism, which facilitates the linear sliding motion of the door panel. The integration of limit switches at both ends of the track provides feedback to the microcontroller, ensuring that the motor stops precisely when the door reaches its fully open or closed positions, thereby preventing mechanical strain.

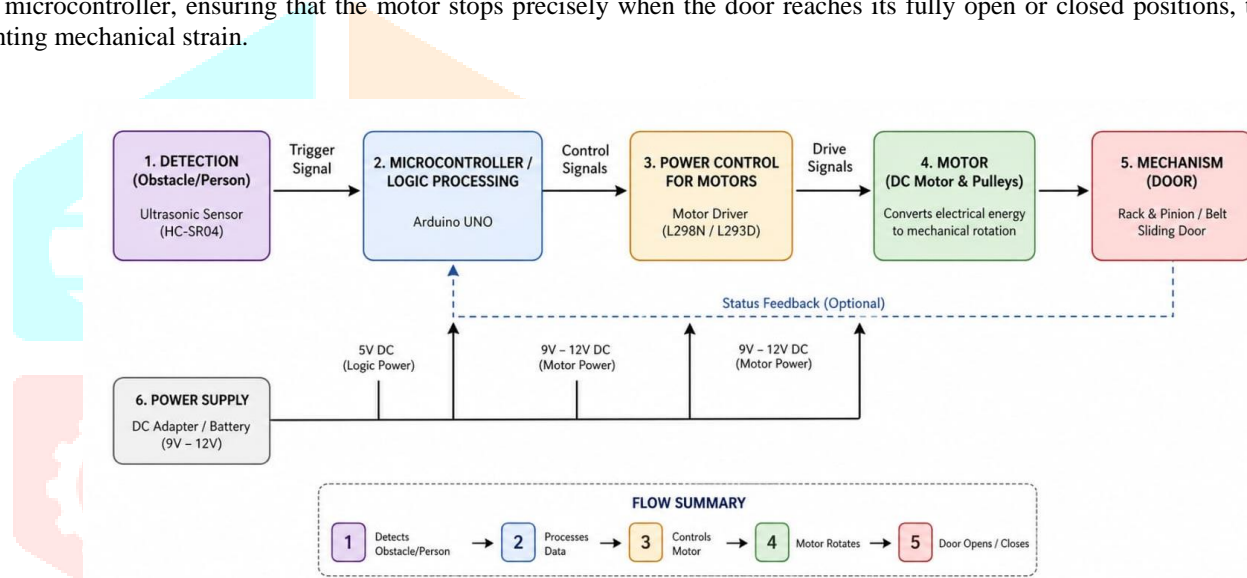

Figure 9 Block diagram automatic sliding door system.

## VI. RESULT AND DISCUSSION

In this paper, the gear (pinion) is connected directly to the motor shaft, and the rack is fixed on the door (gate). This setup is very important because it helps to reduce effort and gives smooth motion. When the motor rotates, the pinion gear also rotates, and it pushes the rack in straight line. Because of this, the door opens and closes easily with less force. This arrangement is better because there is direct contact between gear and rack, so power loss is very low. By placing the gear near the motor and fixing the rack properly on the door, the system works more efficiently. The motor does not need extra power, so energy consumption is less and performance is smooth.

During testing, the system showed the following good results that is given as

- Open and close the door smoothly.
- Required less effort by motor.
- Stable and controlled motion.

Overall, the use of rack and pinion mechanism in correct position makes the system efficient, reliable, and low effort based. Our proposed intelligent automatic door opening system is fully design and work properly which is shown in figures 10 and 11.

The system offers several advantages that make it efficient and user-friendly. It enables contactless operation, allowing doors to open automatically without physical touch, which improves hygiene and helps reduce the spread of germs. It is easy to use and especially beneficial for elderly and physically challenged individuals, as it eliminates the need for manual effort. The rack and pinion mechanism ensures smooth and precise linear motion, while also providing high durability and long-lasting performance compared to pulley or chain systems. Additionally, the system requires low maintenance, making it cost-effective over time. It is energy efficient, as power is consumed only during the opening and closing of the door. The use of sensors and

microcontroller ensures fast response and quick operation. Overall, the system is safe, reliable, and suitable for a wide range of applications, including homes, hospitals, offices, malls, and other public places.



**Figure 10** Overview of the intelligent automatic door opening system.

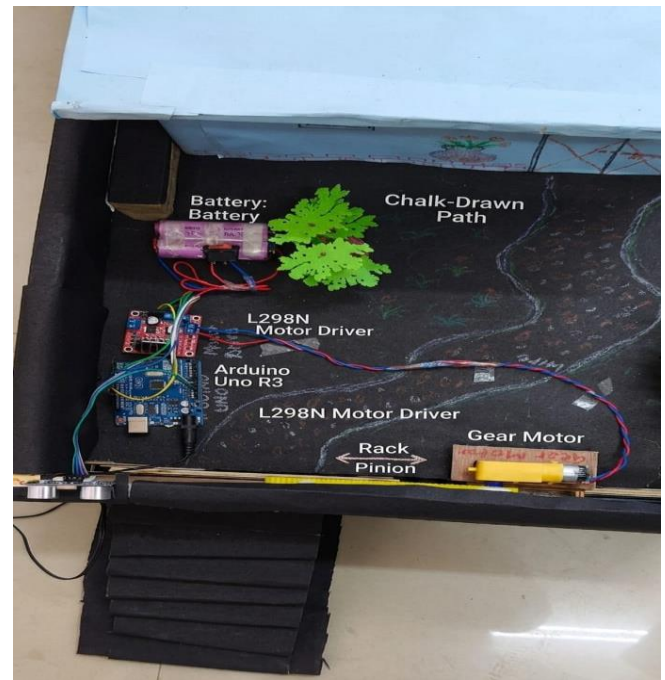

**Figure 11** Design the intelligent automatic door opening system.

The system also has certain limitations that should be considered. It is dependent on a continuous power supply or battery backup; in case of power failure, the door may not operate. The ultrasonic sensor may sometimes face detection issues due to improper angles or environmental conditions, affecting its performance. The initial setup cost is higher compared to a conventional manual door. Additionally, the system is relatively complex as it involves both electronic and mechanical components, making design and installation more challenging. Regular maintenance is required to ensure proper functioning of parts such as the motor, sensor, and gears. There is also a risk of complete system failure if any key component, like the controller or motor driver, stops working. The sensor has a limited detection range, which may cause delays in operation. Furthermore, the system may not be suitable for installation in very small or uneven spaces.

## VII. APPLICATIONS

The automatic door system using rack and pinion mechanism has many useful applications in daily life. It is widely used in hospitals and laboratories where hygiene is very important, as it provides contactless entry and reduces the spread of germs. In shopping malls, airports, and public places, it helps in smooth movement of a large number of people without any delay. This system is also very helpful for elderly and physically challenged individuals, as it removes the need for manual effort. In smart homes, it provides comfort and convenience, especially when hands are full. It is also used in offices and corporate buildings to improve accessibility and give a modern look. In industries and warehouses, it saves time and reduces human effort during movement of goods. Overall, this system is useful wherever automatic, fast, and touch-free door operation is required.

## VIII. CONCLUSION

The automatic door opening and closing system has been successfully developed to provide a modern and efficient solution for entry control. It ensures contactless and hygienic operation, making it highly suitable for public and sensitive environments. The system is fully automatic, requiring minimal human effort, and operates smoothly with the help of a rack and pinion mechanism that provides accurate linear motion. It is designed to be reliable, efficient, and cost-effective, making it accessible for various applications. Overall, the system enhances safety, convenience, and accessibility, offering a practical solution for homes, hospitals, offices, and other public places.

## REFERENCES

- [1] Khurmi, R.S. & Gupta, J.K. (2006). A Textbook of Machine Design. New Delhi: Eurasia Publishing House Ltd.
- [2] Bhandari, V.B. (2009). Design of Machine Elements (3rd ed.). New Delhi: Tata McGraw Hill Education.
- [3] Oladumoye, M., Oluwatobi, A.A. & Obakin, O. (2014). Design and Construction of an Automatic Sliding Door using Infrared Sensor. Computing, Information System Journal, 5(4).
- [4] Smith, J. (2015). Automation in Smart Buildings. International Journal of Engineering Research.
- [5] Chomo, D.I.G., Yawas, D.S. & Johnson, Z.S. (2018). Development of Automatic Door System. American Journal of Engineering Research (AJER), 7(5), pp. 168–173.
- [6] Kumar, A. (2019). Sensor-Based Control Systems in Automation. International Journal of Advanced Technology.
- [7] Lee, B. (2021). Ultrasonic Sensor Applications in Automation Systems. Journal of Modern Electronics.
- [8] Patel, R. (2022). IoT in Smart Automation Systems. International Journal of Smart Technology.
- [9] Jimoh, E. & Aliu, S.A. (2023). Design and Fabrication of an Intelligent Self-Closing and Opening Door. Advances in

Engineering Design Technology, 5(3), pp. 1–21.

[10] Arduino Official Documentation (2026). Arduino UNO and Ultrasonic Sensor Interface Guide.

