



Development Of Crank and Slotted Lever Quick Return Application Mechanism

Prof. Bhimappa Yadahalli, Mandar Pande, Sujit Tayade

¹Asst. Professor Mechanical Engineering Vidya Prasarini Sabha's College of Engineering and Technology, Lonavala

²Student Mechanical Engineering Vidya Prasarini Sabha's College of Engineering and Technology, Lonavala

³Student Mechanical Engineering Vidya Prasarini Sabha's College of Engineering and Technology, Lonavala

ABSTRACT

A quick return system converts rotating motion into reciprocating motion. It consists of two different velocities for its strokes for example working and return. This mechanism is used in machines, for example, shapers and power-driven saws for giving the reciprocating cutting tool a slow cutting stroke and a quick return stroke with a constant angular velocity of the driving crank. Crank and slotted lever mechanism is one of the famous mechanisms for quick return motion to obtain reciprocating motion.

Key Words: *Lever, Link, Quick return mechanism, Slotted bar.*

1. INTRODUCTION

When one link is fixed in a mechanism, the chain is called as mechanism. It could be utilized for transmitting or transforming motion. A mechanism with four links is called as simple mechanism, where as mechanism with more than four links is called as complex mechanism. A mechanism that transforms rotary motion into reciprocating motion at variable rate for its two strokes viz., working stroke and idle stroke is known as quick return mechanism. As the time taken by return stroke is less as compared to its working stroke, it is called as quick return mechanism. This mechanism is generally utilized in machine tools like shaping machines, screw press, power-driven saws, mechanical actuators, revolver system etc. This mechanism comprises of an arm connected to a rotating disc that moves at a controlled uniform velocity. Unlike the crank, the arm of the mechanism runs at a different rate than the plate.

1.1 Crank and slotted lever quick return mechanism

This mechanism is widely utilized in shaping machines, slotting machines as well as in rotary internal combustion engines. In this mechanism (fig. 1), the link AC (i.e. link 3) creating the turning pair is fixed, as given in Fig. The connecting rod of a reciprocating steam engine is associated with link 3. The driving crank CB revolves with constant angular velocity about the fixed center C. AP is oscillated about the pivoted point A due to the sliding block which is connected to the crank pin at B and slides along the slotted bar AP. The motion is transmitted by a short link PR from AP to the ram which conveys the tools and reciprocates along the line of stroke R1R2. The line of stroke of the ram (i.e. R1R2) is perpendicular to AC formed.

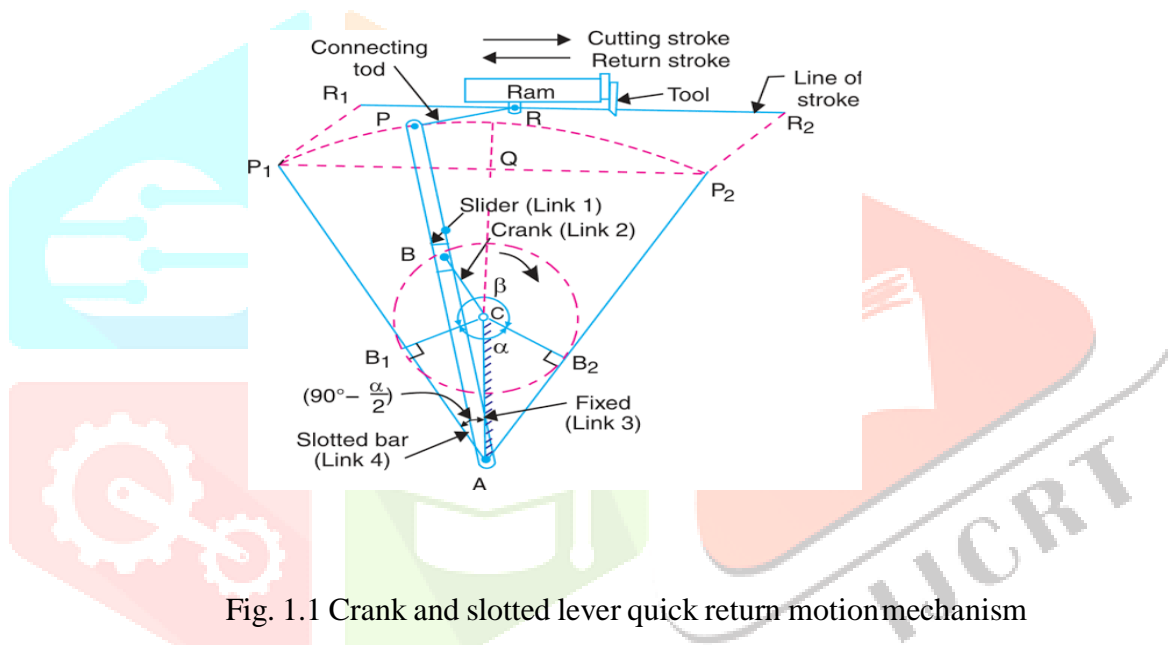

Fig. 1.1 Crank and slotted lever quick return motion mechanism

During extreme positions, the cutting tool is at the end of the stroke and, AP₁ and AP₂ are tangential to the circle. When the crank rotates from the position CB₁ to CB₂, the forward stroke or cutting stroke takes place (or through an angle β) in the clockwise direction. When the crank rotates from the position CB₂ to CB₁, the return stroke takes place (or through angle α) in the clockwise direction. The crank has constant angular velocity, hence

The time ratio is given by -

$$\text{Time ratio} = \frac{\text{Time of cutting stroke}}{\text{Time of return stroke}} = \frac{\alpha}{\beta} = \frac{\beta}{360^\circ - \beta}$$

$$= \frac{360^\circ - \alpha}{\alpha}$$

As the tool covers a distance of R1R2 during cutting and return stroke, travel of the tool or length of stroke is given by

$$\begin{aligned}
 &= R_1R_2 = P_1P_2 = 2P_1Q = 2AP_1 \sin \angle P_1AQ \\
 &= 2AP_1 (\sin 90 - \alpha/2) = 2AP \cos \frac{\alpha}{2} \quad \dots (\because AP_1 = AP) \\
 &= 2AP \times CB_1/AC \quad \dots (\because \cos \frac{\alpha}{2} = \frac{CB_1}{AC}) \\
 &= 2AP \times CB/AC \quad \dots (\because CB_1 = CB)
 \end{aligned}$$

Applications (Engineering Significance) :

Quick return mechanism is used in different machines throughout the engineering industry

- Shaper
- Air Compressor
- Mechanical cutter
- Screw Press
- Power-driven saws
- Mechanical Actuators
- Revolver Mechanism

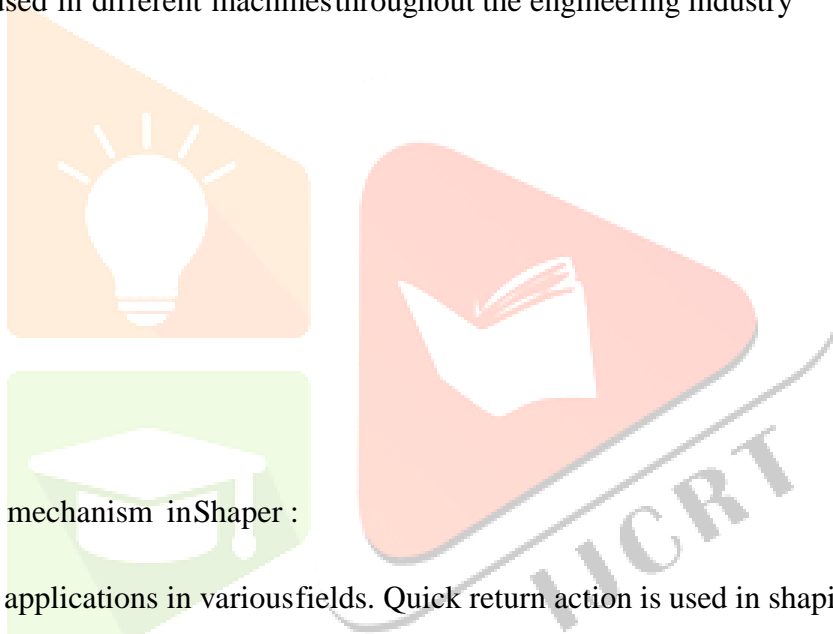

1.1.1 The use of quick return mechanism in Shaper :

Quick return mechanism has applications in various fields. Quick return action is used in shaping machines to minimize the total process time, while its controlled forward action is used for clean and perfect cuts required for shaping.

The quick return mechanism saves time. The cutting process is carried out only during the forward stroke and the speed of the cut varies according to metal being cut. No cutting is done during the return stroke, so the time taken by the return stroke is less as compared to its working stroke. For making the job quicker, freeing up the machine sooner for the next job and increasing profits.

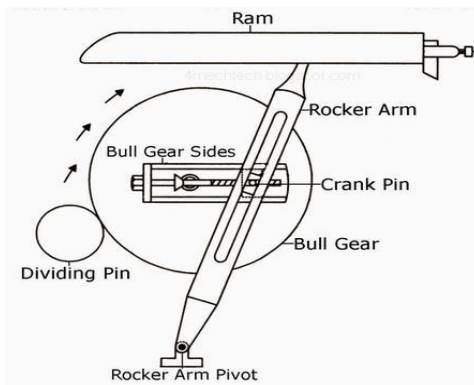

Fig. 1.1.1 Quick return mechanism in shaper

1.1.2 The use of crank and slotted link mechanism in air compressor :

An air compressor converts electrical energy into kinetic energy in the form of air which is held in a highly compressed form before release. We can use the energy released when the compressed air is let out for inflation, cleaning under pressure, turning, generating torque, driving or other similar movement by force. The working principle of an air compressor's is similar to an internal combustion unit. A crankshaft moves a piston through a connecting rod, in a linear fashion along the length of a cylinder in which it fits comfortably. As the piston moves upwards, air is drawn in through an open valve, providing sufficient space for a high volume of air. The valve closes as the piston moves down and the air is compressed. The latter has kinetic energy as it gains high pressure because of the limited space in which it has been forced. The valve opens again to release the energy. The power is increased in proportion as the air goes up. All air compressors must have back up systems to release extra pressure in the event of function in the valve mechanism.

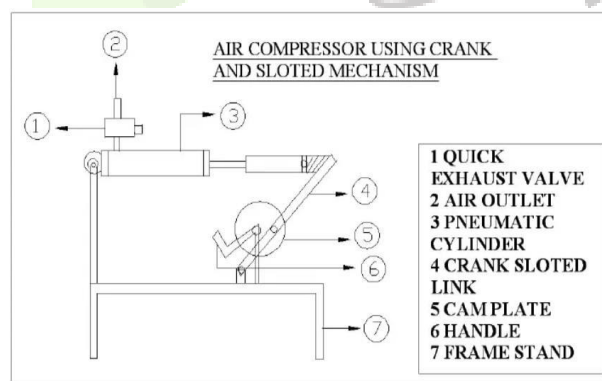

Fig. 1.1.2 Crank and slotted link mechanism in air compressor

1.1.3 Mechanical Cutter using crank and slotted lever mechanism :

The structure of this machine is simple to execute. As such we are planning the agri-shaper machine to reduce human efforts and save time. The working standard behind the activity of straight forward mechanical cutting machine is four bar component particularly crank and slotted lever mechanism. The crank wheel is turned by the engine during the pulley belt assembly. The turning development the crank wheel is changed over into to and fro movement by the coupling join by using the slider. The to and fro movement at the opposite finish of the coupling joint is changed over into responding movement to the sharp edge by using guide opening. Design thinking is becoming critical for the well-being of the society and the nation.

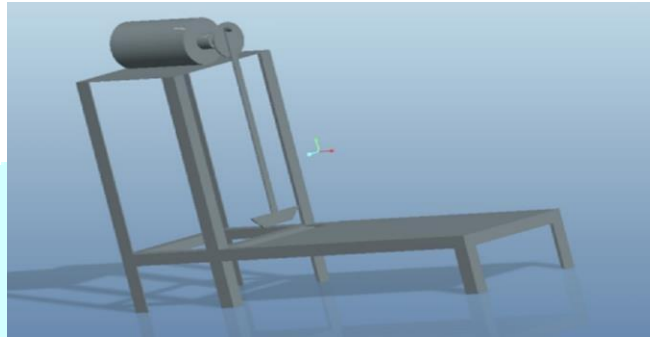

Fig. 1.1.3 Mechanical cutter using crank and slotted lever mechanism

CONCLUSION

Quick return ratio is limited to strength of the material. By incorporating stronger materials, QRR can be increased. Backlash can be minimized by choosing closed tolerances and proper assembly techniques. With increase in slider height QRR increases. Friction at the interface of guide ways and ram can be minimized by using turcite tape. Ram velocity varies from zero at beginning, maximum at middle of the stroke and zero at the end.

REFERENCES

- [1] Mailander, M., Benjamin, C., Price, R., & Hall, S. (2010). Sugar cane yield monitoring system. *Applied Engineering in Agriculture*, 26(6), 965–969.
- [2] Masute, R. J., & Khedkar, P. S. S. (2015). *Journal of Mechanical and Civil Engineering Design and Fabrication of Small Scale Sugarcane Harvester*, (3), 1–9.
- [3] Wilson, D. G. (2019). Understanding Pedal Power. *Journal of Chemical Information and Modeling*, 53(9), 1689–1699.
- [4] Xu, L., Bai, W., Ru, J., Li, Q., & Li, J. (2011). Design and implementation of the reciprocating pedal-powered electricity generating device. *Advanced Materials Research*, 282–283, 735–738.

Chaudhary Pravinkumar k, “Understanding pedal power” ISBN: 0- 86619268-9 [C], Volunteers in Technical Assistance” Technical paper 51 VITA 1600 Wilson Boulevard USA, 1986.

- [5] Layer, J., Adler, T., et al, ASM Handbook-Failure Analysis and Prevention, 11 ed. ASM International, 2002; 14–65.
- [6] Boyer, H.E. et al, Metals Handbook 10-Failure Analysis and Prevention, eighth ed. American Society for Metals, 1975; 1–10.
- [7] S.G.Bahaley, Dr.A.U.Awate, S.V.Saharkar, “Performance Analysis of Pedal Powered Multipurpose Machine”, International Journal of Engineering Research and Development (IJERD) (Vol.1, Issue.5,e-ISSN:2278-0181), 2012.
- [8] Zoeb khan, “Design and Fabrication of Human Powered Wood Cutting machine” International Journal on Recent and Innovation Trends in Computing and Communication ISSN: 2321-8169, 3(2): 072– 074.
- [9] N.M. Pachkhande, Dhiraj V. Rade, Vikas G. Nagapure, Small scale sugarcane cutter machine, Int. J. Eng. Appl. Technol. (2015).
- [10] Linder, C., Armero, F., 2009. Finite elements with embedded branching. Finite Elem. Anal. Des. 45 (4), 280293.
- [11] Travas, V., Ozbolt, J., Koz ar, I., 2009. Failure of plain concrete beam at impact load: 3D finite element analysis. Int. J. Fract. 160 (1), 31 41 (Date: 26 Sep. 2009).
- [12] Leonel, E.D., Venturini, W.S., Chateauneuf, A., 2011. A BEM model applied to failure analysis of multi-fractured structures. Eng. Fail. Anal. 18, 15381549
- [13] Shelare, S. D., Thakare, P. S., Handa, C. C., & Professor, A.(2012). Computer Aided Modelling and Position Analysis of Crank and Slotted Lever Mechanism. International Journal of Mechanical and Production Engineering Research and Development, 2(2), 47–52.