



# Railway Track Crack Detection System

<sup>1</sup>Likhitha U N, <sup>2</sup>Pavan Kumar V, <sup>3</sup>Prajwal Y, <sup>4</sup>Punith MR, <sup>5</sup>Shashank G  
<sup>1</sup>Assistant professor, <sup>2</sup>UG Student, <sup>3</sup>UG Student, <sup>4</sup>UG Student, <sup>5</sup>UG Student  
Department of Electrical and Electronics Engineering,  
<sup>1</sup>Sri Siddharatha Institute of Technology, Tumkur, India

**Abstract:** This project discusses a Railway track crack detection using sensors and is a dynamic approach which uses the WEB tracking system to send alert WEB messages and the geographical coordinate of location. An Arduino Microcontroller is used to control and coordinate the activities of this device. In India railways transportation service is the cheapest and most convenient mode of passenger transport as well as for long distance and suburban traffic. Almost 80% of the transport in India is being carried out by railway network. The main cause of the accidents happened in railways are railway track crossing and unidentified crack in rail tracks. About 60% accidents are happened at railway track crossing and due to crack in railway tracks resulting in loss of precious life of passengers and loss of economy. Therefore, there is a need to have new technology which will be robust, efficient and stable for both crack detection in railway tracks as well as object detection.

**Index Terms** - WEB, Track, Railway crack

## I. INTRODUCTION

In India the railway network has a track length of 113,617 kilometers (70,598 mi) over a route of 63,974 kilometers (39,752 mi) and 7,083 stations. This is the fourth largest railway network in the world. The Rail transport is growing at a rapid pace in India. It is one of the major modes of transport but still our facilities are not that accurate, safer as compared to international standards. A survey on the internet states that about 60% of all the rail accidents is due to derailments, recent measurements shows that about 90% are due to cracks on the rails. Hence, it is not safer for Human Life. This needs to be at the utmost attention. These goes unnoticed and the properly maintenance of tracks is not done manually, but the proposed system has a robot which will run automatically on the tracks. System having LED and LDR sensor assembly, but the main disadvantage is that the LED and LDR must be placed opposite to each other and also the environment needs to be perfect to detect the track. To overcome this disadvantage, here proximity sensor is used, which will detect the crack accurately. The existing system is slow, tedious and time consuming. This system has GPS module which will give the real time location or coordinate to the nearest railway station.

## II. PROBLEM STATEMENT

A broken train speaks about one of the world's major causes of more expensive and dangerous rail accidents. Taking into account incidents in general, all considered in us alone, for every three days there is more than one major demolition, consistently over 10 years. Accessible interventions when the broken track clashes in different countries are disrupted do not sufficiently help to understand the political, social and ecological effects. In the current framework, when the track is open, the framework is forced to hurry up and

out along the track at irregular intervals. Often, it will send an exception flag to the technician using a remote module just in case something stands out divided on the line. Divisions are detected by IR sensors and the error flag is conveyed.

### III.PROPOSED SYSTEM

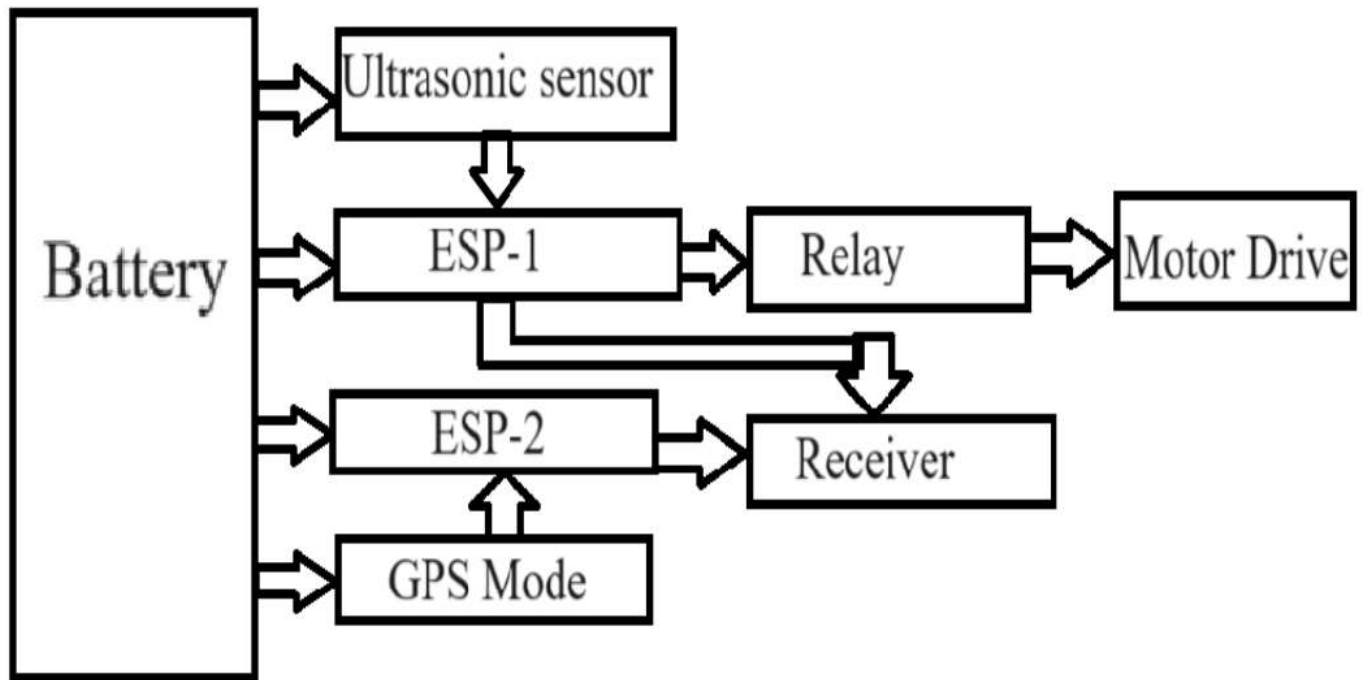

Fig.1.Block diagram

The main aim of project is to design the railway crack detection using Ultrasonic sensors. The project block diagram is shown, in which contains microcontroller (Arduino), ultrasonic sensor, motor driver, motor, GPS module when the crack is detected, relevant geographical location coordinates will send to the nearest station. This recording and sending of coordinates are done by GPS module. GPS network used by cell phones provides a low cost, long range wireless communication channel for applications that require connectivity rather than higher data rates. Infrared transmitter is one type of the LED which emits infrared rays generally called IR transmitter. Initially the tracks are being continuously monitored with the help of sensor, which is used to detect the crack inside the track. This monitoring is done with the help of ultrasonic sensor in order to sense the minor changes Whenever the crack gets detected with the help of ultrasonic sensor it passes the alert of crack found to the Arduino microcontroller. The Arduino microcontroller will perform the process mainly includes positioning and sending alerting through the help of GPS module. As data gets delivered to the Railway Authority, the alert is to be taken into account and important measures must be taken by the railway authority in order to avoid future accidents.

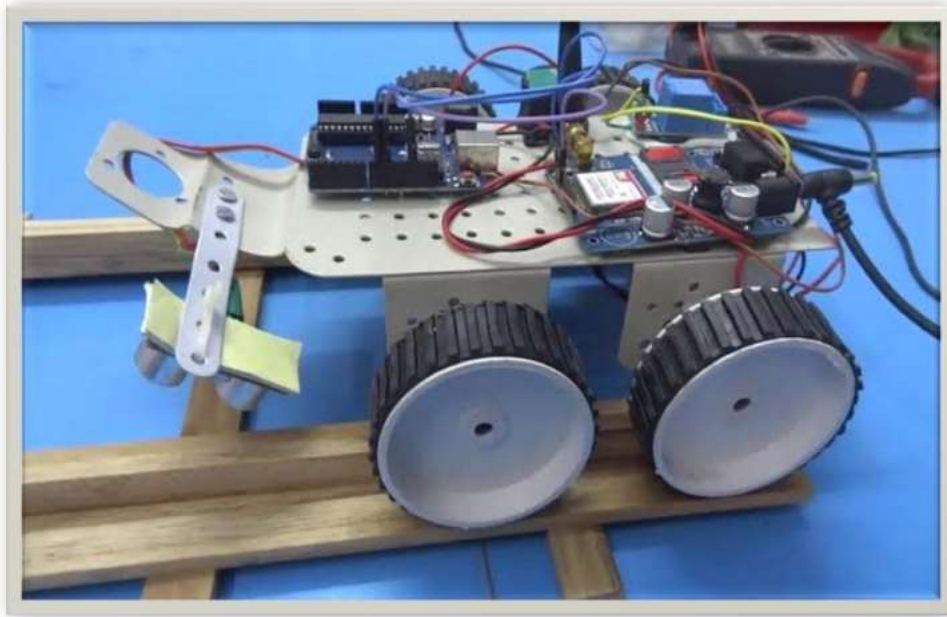

Fig.2.Working Module of Railway Track Crack Detection System

#### IV. MERITS

- The auto crack detection method is more efficient in the technical field.
- Simple in construction and Easy to maintain and repair.
- Comparatively the operation cost is less.
- Continuous operation is possible without stopping.
- Automatic alert system to the station master.

#### V. CONCLUSION

This project was one of the golden opportunities that prompted not only to gain knowledge on different topics and learn a fair number of new technologies but also put them into practice. It was a great way for us to apply all the skills and knowledge. We managed conducting a feasibility study, gathering requirements by prioritizing them, designing and implementing the project, and eventually testing it.

In this paper we have presented a crack detection for railway tracks using ultrasonic sensors Also the location of the crack or fracture using GPS. This way the authorities can be able to solve the issue hands on. This improves the efficiency of railway track maintenance. Another advantage is that it can be applicable during day as well as night. It will increase the area covered for rail maintenance in one day by using it during day and night. The idea can be implemented in large scale application with better management of the resources available by the railway maintenance department, so that rail transport can become much safer and smoother mode.

**REFERENCES**

1. A. L. Polivka and W. L. Matheson, "Automatic train control system and method", U.S.Patent No. 5828979, (2014) October 27.
2. Nilisha Patil, Dipakkumar Shahare, Shreya Hanwate, Pranali Bagde, Karuna Kamble, Prof. Manoj Titre (2021). "Designing of Improved Monitoring System for Crack Detection on Railway Tracks" Proceedings of the Third International Conference on Intelligent Communication Technologies and Virtual Mobile Networks (ICICV), IEEE Xplore Part Number: Cfp21ONG-ART; 978-0-7381-1183-4
3. Rahul Singh, Leena Sharma, Vandana Singh, Vivek Kr. Singh. (2020), "Automatic Railway Track Crack Detection System" International Journal of Engineering Research & Technology, VoL.07.
4. Arun Kumar R, Vanishree K, Shweta K, Nandini C, Shweta G. (2020), "Railway Track Crack Detection", Proceeding of National Conference on advancements in Informational Technology (NCAIT), ISSN-2278-0181.
5. An Arduino based Method for Detecting Cracks and Obstacles in Railway Tracks" by Er.Kunduru Uma Maheswari and Er.Polepogu Rajesh, International Journal of Electronics, Electrical and Computational System, Volume 6, April 2017.
6. Shailesh D. Kuthe, Sharadchandra A. Amale, Vinod G. Barbuddhye "Modern Method for Detecting Cracks in Railway Tracks by The Efficient Utilization of LDR And LED System" Advance Research in Electrical and Electronic Engineering, Volume 2, Number 5; April – June, 2015.
7. Ravi Shankar Shekhar, Purushottam Shekhar, Ganesan P, "Automatic Detection of Squats in Railway Track", IEEE Sponsored 2nd International Conference on Innovations in Information Embedded and Communication Systems. vol.3, issue. 6, December 2015
8. S. Srivastava, R. Chaurasia, S. Abbas, P. Sharma and N. Singh, "Railway Track Crack Detection Vehicle", International Advanced Research Journal in Science, Engineering and Technology, vol. 4, no. 2, pp. 145-148, 2017.