



AUTOMATIC BRAKING SYSTEM AND DRIVER SAFETY

K SHASHANK AITHAL

Student

Department of Information Science and Engineering
Dr Ambedkar Institute of Technology
Bangalore-560056, Karnataka, India

YASHAS M

Student

Department of Information Science and Engineering
Dr Ambedkar Institute of Technology
Bangalore-560056, Karnataka, India

HARSHA M

Student

Department of Information Science and Engineering
Dr Ambedkar Institute of Technology
Bangalore-560056, Karnataka, India

M SAIVISHNU SARODE

Student

Department of Information Science and Engineering
Dr Ambedkar Institute of Technology
Bangalore-560056, Karnataka, India

Mrs. RAJESHWARI

Asst. Professor

Department of Information Science and Engineering
Dr Ambedkar Institute of Technology
Bangalore-560056, Karnataka, India

Abstract: Vehicle accidents often occur due to the sudden appearance of obstacles while driving. The varying response times of drivers can result in delayed braking or an inability to stop in time, leading to collisions. To address this issue, we propose an Autonomous Braking System (ABS) that utilizes advanced mechatronic technology. The system uses an Ultrasonic wave emitter at the front of the vehicle to send out Ultrasonic waves. When these waves hit an obstacle, they bounce back and are detected by an Ultrasonic receiver. By analyzing these reflected signals, the system calculates the distance to the obstacle and adjusts the vehicle's speed accordingly through a microprocessor. In emergency situations, the microcontroller takes control and activates the braking system to apply the brakes quickly and effectively, enhancing safety. An important enhancement to this system is the integration of a Python-based application using Flask. This application can dynamically determine the location of an incident and communicate it to the nearest emergency services using real-time geographical data. This communication is facilitated through GSM technology, which sends alarm signals and the vehicle's GPS location to the appropriate authorities, ensuring a prompt response and assistance. Additionally, the system can be expanded to include inter-vehicle communication capabilities. This feature allows cars to share information about their locations and speeds, improving road cooperation and awareness. This not only reduces collisions but also helps in creating smoother traffic flow. Overall, the Autonomous Braking System aims to improve road safety by reducing response times and stopping distances, thereby preventing accidents and significantly enhancing emergency response capabilities.

Keywords— Autonomous Braking System, Emergency Braking, GSM Technology, GPS Location Tracking Ultrasonic Technology, Obstacle Detection.

I. INTRODUCTION

The rise in traffic accidents, despite advancements in car technology, underscores the urgent need for innovative solutions to enhance driver safety. One significant advancement in vehicle safety is the development of autonomous braking systems designed to reduce the risks posed by unforeseen obstructions on the road. Our research focuses on implementing a fully automated braking system using intelligent control mechanisms and cutting-edge technologies to address this need.

Traditional braking systems, while essential, often lack the rapid response time necessary to effectively handle unexpected dangers, putting drivers at risk of collisions. To overcome this limitation, we propose an automated braking system operated by Arduino UNO microcontrollers equipped with ultrasonic sensors. This system can detect obstacles in real-time and perform autonomous braking, thereby reducing the likelihood of crashes and minimizing the severity of accidents.

The increasing frequency of traffic incidents, particularly in urban areas, also highlights the urgent need for improved emergency response systems. Our proposed solution adopts a multipronged approach, incorporating features such as an advanced Driver Safety Module and automated accident detection and alerting. This comprehensive system ensures prompt communication with emergency

services and medical facilities, enhancing post-accident support and mitigating the impact of accidents on affected individuals and communities.

By integrating these advanced features, our automated braking system provides a robust and technologically sophisticated method for improving road safety and reducing the likelihood of accidents. Our ongoing research and development efforts aim to further refine and optimize the system to meet the evolving demands and challenges of modern transportation networks.

Our study aims to develop and deploy an innovative autonomous braking system to address the dual challenges of enhancing driver safety and improving emergency response capabilities. By leveraging state-of-the-art technologies and proactive safety measures, we aspire to contribute to making roads safer and creating a more secure transportation environment for everyone. Continuous research and development will ensure that our system remains at the forefront of traffic safety innovations, ultimately saving lives and enhancing the driving experience.

II. OBJECTIVES

- To develop an Intelligent Braking System for Automobiles
- To find the braking distance at various vehicle speeds as well as minimum distance before collision
- To instantly rescue accident victims by sending a message to the rescue team with a MEMS accelerometer GSM and GPS.
- Designing and implementing the notification mechanism for GSM

III. LITERATURE SURVEY

In recent years, there has been a growing focus on developing methods to prevent auto accidents and monitor drivers' health in real-time. Research has explored various technologies, such as integrating lidar, radar, and ultrasonic sensors to identify road hazards. Using machine learning algorithms to predict accidents, and developed wearable health devices to monitor drivers vital signs for signs of fatigue or impairment, all aimed at enhancing road safety.

Automatic road accident detection systems are essential for reducing response times and minimizing collision severity. Research has highlighted the effectiveness of ultrasonic sensors in detecting accidents and providing real-time data to emergency services. Integration with GPS and GSM technology has been explored to facilitate rapid location tracking and alert authorities. While promising, further research is needed to optimize these systems for widespread use.

The literature on CHD diagnosis parallels the examination of methods for detecting traffic accidents. It highlights the importance of quickly and accurately identifying incidents to improve emergency response, using sensor networks like GPS accelerometers to detect sudden vehicle motion changes. Challenges such as false alarms and accuracy in various conditions remain.

Smartphone technology has gained attention for enhancing traffic safety. The Wreck Watch study introduced using smartphones as sensors to detect accidents in real-time, providing rapid detection, precise location tracking, and automatic emergency notification. Subsequent research has improved these systems' accuracy and reliability and integrated them with existing emergency response infrastructure.

Studies on GPS and GSM technology have proposed automated systems for accident detection and notification, emphasizing their importance in accelerating emergency response and reducing accident severity. Research on adaptive control mechanisms for autonomous driving has explored sensor fusion methods and machine learning algorithms to improve obstacle detection and predictive control.

In conclusion, the literature underscores the potential of advanced sensor systems, machine learning, and smartphone technology to enhance traffic safety, improve emergency response, and reduce the impact of accidents on individuals and communities.

IV. Methodology

To develop an automatic braking system, begin by outlining project objectives, considering factors like performance metrics, vehicle type, and safety standards. Conduct a feasibility study, evaluating technical, economic, and operational aspects. Gather detailed requirements from stakeholders, focusing on vehicle dynamics and environmental conditions. Design the system architecture, selecting components like radar, cameras, and control units based on performance and reliability. Develop control algorithms for object detection and collision prediction. Build and test a prototype, analyzing performance under various conditions. Iterate on design and algorithms based on test results and user feedback. Ensure compliance with safety regulations through collaboration with authorities.

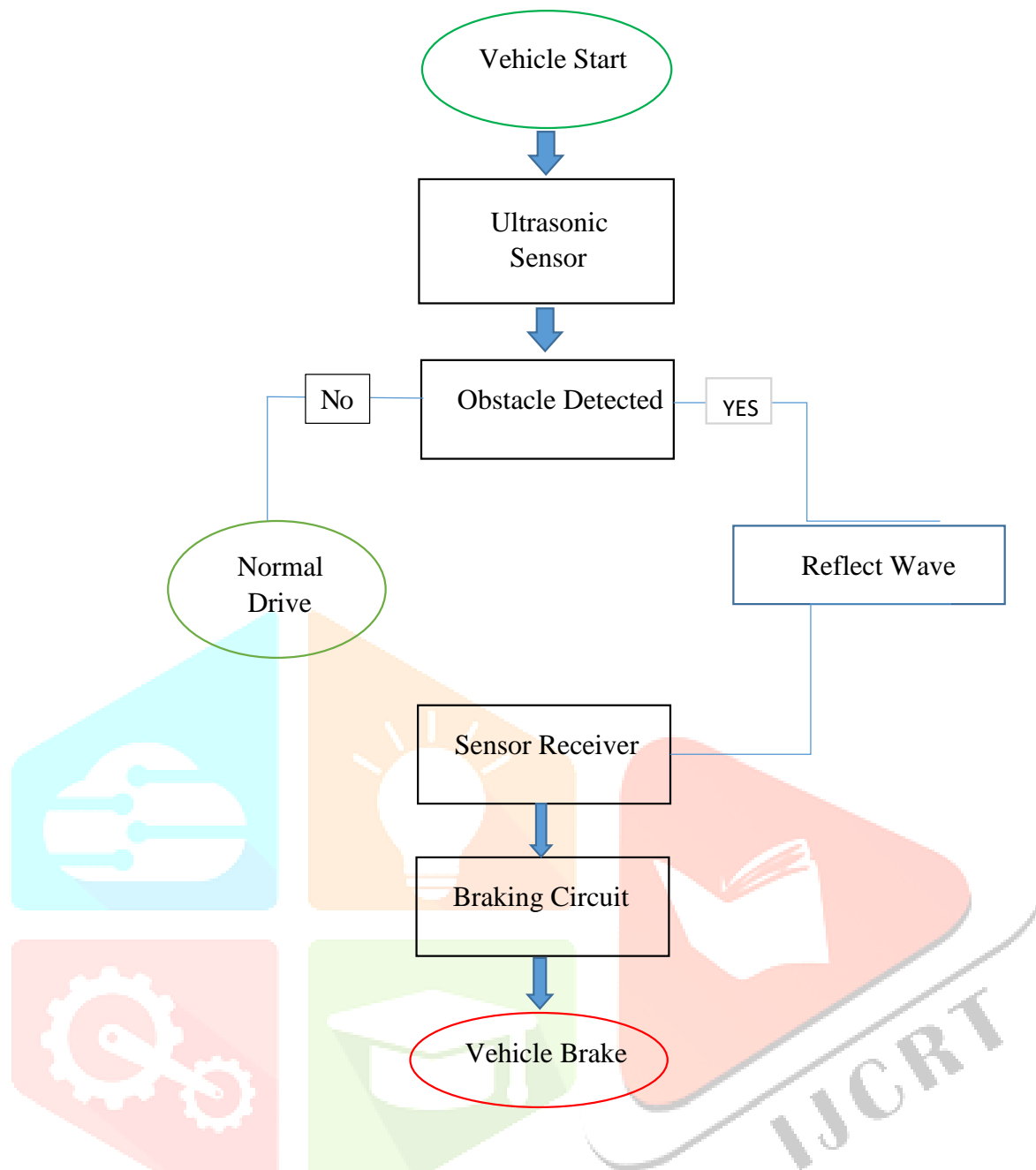

For a driver safety project, define objectives such as reducing accidents and improving driver behavior. Set measurable targets and develop a comprehensive safety plan, incorporating education programs and technological solutions like collision warning systems. Allocate necessary resources and deploy technologies, launching awareness campaigns to promote safe driving practices. Establish a data collection system to monitor outcomes and continuously evaluate the project's effectiveness, collaborating with stakeholders for input. Periodically assess impact and share reports with relevant parties to communicate progress and recommendations.

V. System Overview

The Automatic Braking System and Driver Safety project seamlessly integrate several crucial components to enhance traffic safety and prevent collisions. At the heart of the system is the Arduino UNO ATMEGA 328p microcontroller, programmed using embedded C, which orchestrates the system's core functions. Central to its operation is the DC motor, controlled by the microcontroller, acting as a responsive brake mechanism, allowing for adaptive adjustments to the brake pedal as needed.

Critical to accident prevention is the HC-SR04 ultrasonic sensor, employing ultrasonic waves to precisely detect obstacles in the vehicle's path and relay real-time data to the microcontroller for prompt brake responses. Additionally, the system incorporates Driver Safety Module equipped with a crash detection unit, utilizing a three-axis accelerometer, a position encoder, and a fire sensor to swiftly identify accident scenarios

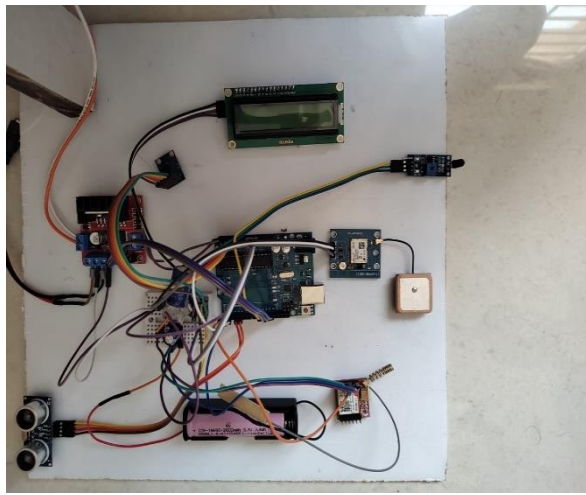
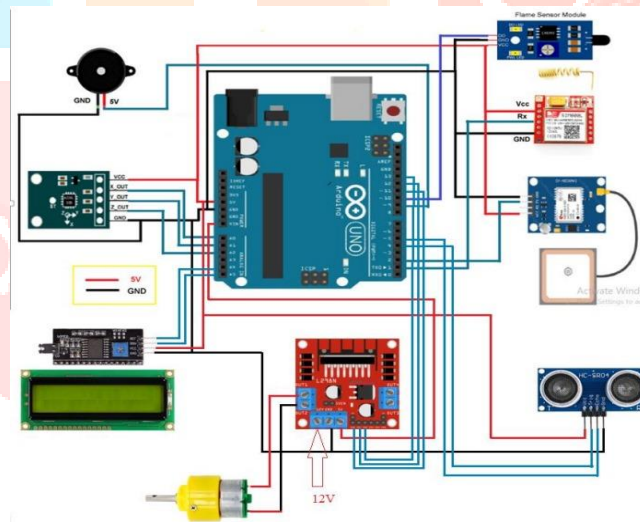

Fig. 1. System Overview

In the event of an accident, notifications are sent to an Android app, facilitating quick communication with hospitals and emergency services to ensure prompt assistance for those involved. An integrated 16x2 LCD monitor provides user interaction and feedback, while the I2C module enables seamless communication between peripheral devices, ensuring smooth data transmission and system integration.

Through the meticulous integration of these components, meticulously designed, the automated braking system and driver safety initiative ensure efficiency and reliability, significantly bolstering traffic safety measures and accident avoidance strategies.

VI. Circuit Diagram



The Automatic Braking System and Driver Safety project's circuit diagram comprises vital components, each contributing to its functionality. At its core is the Arduino UNO ATMEGA 328p microcontroller, programmed in embedded C, orchestrating various hardware elements. A DC motor, regulated by the microcontroller, operates the braking mechanism via a motor driver, adjusting the brake pedal position. An HC-SR04 ultrasonic sensor detects obstacles, relaying real-time feedback to the microcontroller for brake activation. The Driver Safety Module, with a crash detection unit, employs sensors like a position encoder, fire sensor, and three-axis accelerometer to identify accidents swiftly. An Android app receives alerts during accidents, aiding quick communication with emergency services. A 16x2 LCD display offers user information and feedback, enhancing engagement. The I2C module enables seamless communication between the microcontroller and peripherals. Together, these components ensure the efficacy and reliability of the driver safety project and automatic braking system, bolstering road safety and accident prevention efforts.

VII. System Implementation

To develop an advanced automatic braking system with improved emergency communication, a structured approach is essential. The project aims to dynamically communicate with nearby emergency services based on accident location, necessitating clear objectives and performance metrics such as response time reduction and alert accuracy.

A feasibility study assesses integrating Python-based geolocation processing into the existing system, considering technological, cost, and regulatory aspects. Stakeholder engagement refines system requirements, considering regional accident dynamics and local emergency service integration.

System design updates include a geolocation module seamlessly integrated with existing components like ultrasonic sensors and microcontrollers. Hardware and software components are selected, including GPS modules, GSM enhancements, and a Flask-based server backend for real-time data processing.

Algorithm development focuses on accurately identifying the nearest emergency responder based on real-time location data and predefined geospatial databases. Integration and testing ensure system functionality in simulated real-world scenarios, evaluating accident detection, emergency communication, and braking execution.

Iterative improvement based on testing feedback enhances system accuracy, communication latency, and overall robustness. Certification and compliance ensure adherence to safety and regulatory standards, particularly concerning new components' impact.

Project expansion may include inter-vehicle communication to enhance preventive measures by sharing location and hazard information in real time. These steps not only enhance the automatic braking system but also significantly improve emergency response capacity through intelligent and location-aware communication strategies.

VIII. System Testing

Scenario 1: Car Accident Alert

Test Objective: To verify that the system sends a message to the provided phone numbers through GSM in the event of a car accident, containing the accurate location of the accident.

Test Steps:

- Simulate a car accident scenario.
- Trigger the system to recognize the accident.
- Ensure that the system retrieves the location of the accident from the GPS module.
- Verify that the system activates GSM communication.
- Confirm that the message sent contains the text "Car Accident Alert at [location of the car]".

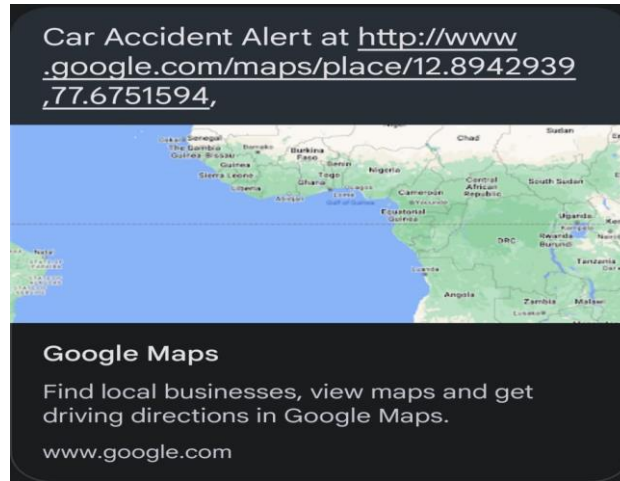
Message:**Scenario 2: Car Fire Alert**

Test Objective: To confirm that the system sends a message through GSM in the event of a car fire, providing the correct location of the fire.

Test Steps:

- Simulate a car fire scenario.
- Activate the system's fire detection mechanism.
- Ensure that the system retrieves the location of the fire from the GPS module.
- Verify that the system initiates GSM communication.
- Confirm that the message sent contains the text "Car Fire Alert at [location of the car]".
- Expected Result: The system successfully sends a message containing the accurate location of the car fire to the provided phone numbers through GSM.

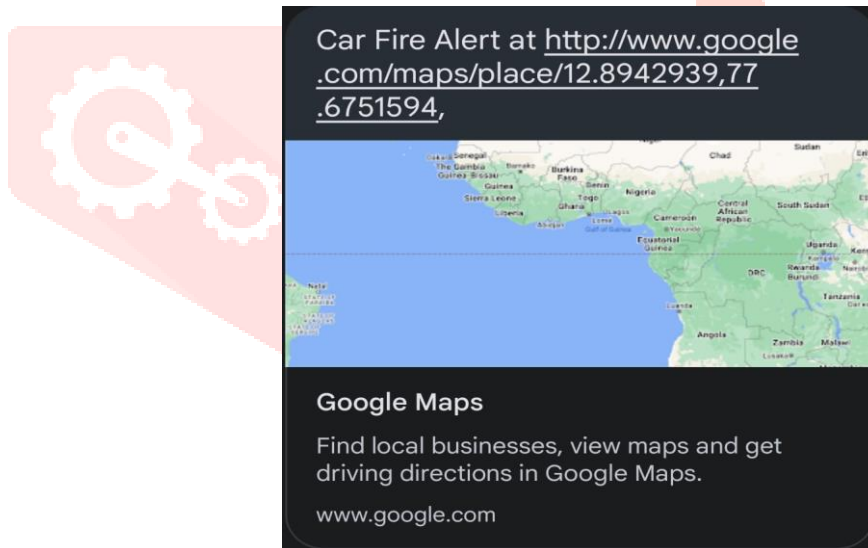
Message:**Scenario 3: Emergency Braking Activation**

Test Objective: To validate that the system activates emergency braking effectively when an obstacle is detected.

Test Steps:

- Position an obstacle in the path of the vehicle.
- Monitor the system's response to the obstacle.
- Ensure that the system detects the obstacle using the Ultrasonic sensors.
- Verify that the system calculates the appropriate braking force based on the obstacle's distance.
- Confirm that the emergency braking system engages promptly and decisively.

Expected Result: The system successfully detects obstacles, calculates braking force, and engages emergency braking promptly, ensuring safety.

These scenarios cover key functionalities of the Automatic Braking System and Driver Safety using Arduino UNO.

IX. RESULTS AND ANALYSIS

In evaluating the upgraded automatic braking system and driver safety project, extensive testing was conducted to assess its performance and effectiveness. The testing setup included calibration of components like ultrasonic sensors, GPS, and GSM modules, ensuring accurate data collection and system functionality. Various scenarios were simulated to test adaptability and responsiveness, particularly focusing on emergency situations.

Data collection involved assessing obstacle detection, location accuracy, and communication efficacy. Results indicated successful activation of braking and alert systems, though delayed responses and occasional inaccuracies were noted, highlighting areas for improvement. Performance metrics such as response time and emergency notification accuracy were analyzed to gauge system effectiveness. Iterative improvements were planned based on test insights, aiming to reduce latency and enhance overall safety and emergency responsiveness. This comprehensive evaluation provides valuable insights for future enhancements to the system's functionality and reliability.

X. CONCLUSION AND FUTURE SCOPE

In conclusion, the successful fabrication of our automatic braking system prototype marks a significant step towards improving road safety. By implementing an Automatic Braking System for forward collision avoidance, we aim to reduce accidents and save lives, especially in scenarios where manual braking may not be possible. Practical implementation has provided valuable insights, paving the way for future advancements in speed control systems for automobile safety. The incorporation of all system components maximizes safety and market competitiveness. Future work involves refining the system with ultrasonic sensors for broader vehicle application and enhancing emergency response capabilities. Additional features such as route optimization algorithms, first aid kits, and medical monitoring modules aim to further improve system performance and effectiveness in preventing accidents and providing timely assistance.

XI. REFERENCES

1. CAR ACCIDENT DETECTION SYSTEM USING GPS AND GSM ,Jan-Feb 2015, Vikram Singh Kushwaha, Deepa Yadav, Abusayeed Topinkatti, Amrita Kumari.
2. GSM based Vehicle Accident Alert System, Jan 2021, G. Boopathi Raja, Keerthika A, Keerthika S G, Nandhini A, Pranitha K J
3. Development of An Automatic Bumper And Braking System For Vehicles Using Pneumatics System To Avoid Collision ,May 2021, Prabhu R, Senthil Kumar M, Sekar J
4. ACCIDENT ALERT SYSTEM USING GPS AND GSM, May 2022, Ravisankar T, Siva prasath S, Srinidhi S, Yaswanthkumar A, Mr.Anbarasan A
5. Automatic Braking System , June 2022, DR. K. MALLIKARJUNA, T. MANOJ KUMAR, E. SIVA SAI, E. KRISHNA PRASHANT, N. ROHITH, S.M. PARVEZ RIZVI. CAR ACCIDENT DETECTION SYSTEM USING GPS AND GSM ,Jan-Feb 2015, Vikram Singh Kushwaha, Deepa Yadav, Abusayeed Topinkatti, Amrita Kumari.
6. GSM based Vehicle Accident Alert System, Jan 2021, G. Boopathi Raja, Keerthika A, Keerthika S G, Nandhini A, Pranitha K J
7. Development of An Automatic Bumper And Braking System For Vehicles Using Pneumatics System To Avoid Collision ,May 2021, Prabhu R, Senthil Kumar M, Sekar J
8. ACCIDENT ALERT SYSTEM USING GPS AND GSM, May 2022, Ravisankar T, Siva prasath S, Srinidhi S, Yaswanthkumar A, Mr.Anbarasan A

9. Automatic Braking System , June 2022, DR. K. MALLIKARJUNA, T. MANOJ KUMAR, E. SIVA SAI, E. KRISHNA PRASHANT, N. ROHITH, S.M. PARVEZ RIZVI.

